

# IME 330 Manufacturing Processes I

## EXAMINATION C

POINTS  
out of 100

Dr. Valery Marinov

Spring 2002

### Student:

- Answer all of the following questions/problems. Answers should be logically organized, concise, and brief.
- Total points for this examination are 100. The weight of each question is indicated by the number of points assigned to the question; use this as a basis for determining how much effort to place on answering each question.
- This examination is “open-book; open-notes; closed neighbor”, i.e., you may use any written materials that you might find useful.
- You may not discuss the exam with any of your colleagues; I want your thoughts alone in this final—thus you can not work in groups.
- You must give and sign the following Honor Pledge (or your exam paper will not be accepted):

**On my honor as a student, I have neither given nor received given assistance on this examination. I have followed all rules outlined on the exam itself, as well as commonly accepted rules of academic honesty and integrity. I understand that failure to follow both sets of rules constitutes cheating on this assignment.**

**It is my Honor Pledge** \_\_\_\_\_

Good luck!

### Q1. Bending (34 pts)

A sheet-metal blank of width  $w=5$  mm is to be bent in a V-bending operation as shown in the figure. The metal has a tensile strength of 200 MPa.

DETERMINE:

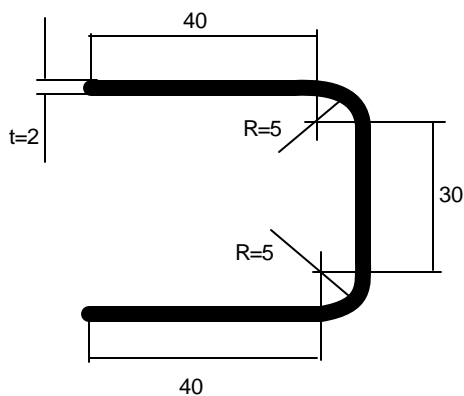

a) The starting blank size (20 pts)

b) Bending force if the die opening dimension is  $D=100$  mm. (14 pts)

**Q2. Forging (24 pts)**

a) Draw a simple sketch to illustrate what "flash" is in forging. (9 pts)

b) Explain what purpose the flash serves in the impression die forging operation. (15 pts)

**Q3. Casting (42 pts)**

Gray cast iron is used to cast the part pictured below, basically a cube with a blind pocket (all dimensions are in mm). Casting is made with the metal poured at very low superheat (i.e. just above the alloy liquidus line).

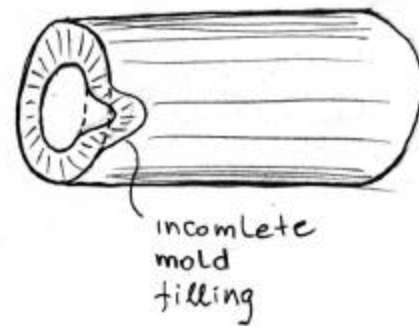
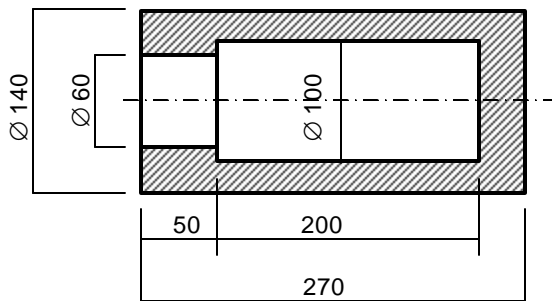

(a) Estimate the time required casting to solidify assuming the mold constant  $C_m = 0.1 \text{ min/mm}^2$  (7 pts)

- (b) Select the most appropriate place for a cubical riser and calculate its dimensions assuming that it will solidify 2 min after the casting. (10 pts)
- (c) Sketch a sand mold needed to cast the part, showing the parting line, gating system, riser, cores, vents, etc. (10 pts)
- (d) Dimension the mold cavity and the cores using the appropriate shrinkage allowance (5 pts)
- (e) Identify the causes of the defect pictured here. Briefly describe your idea of what to do to prevent this defect. (10 pts)