

Temporary Grain Storage

Dr. Kenneth J. Hellevang, PE
Extension Agricultural Engineer

The purpose of any grain storage facility is to prevent grain quality loss from weather, wind and moisture; rodents, birds and insects, and microorganisms.

Various techniques and facilities have been used to store grain temporarily. Generally, the more durable the facility, the longer grain can be stored without excess loss.

Manitoba agricultural engineers studied losses in different temporary grain storages of wheat, barley and oats. Losses in an uncovered outdoor pile were about 50%. Losses were 1-4% for temporary bins set on a plastic sheet and covered with a plastic sheet. Venting out moisture at the top of the covered grain pile may be needed. Grain piled in a smooth cone shape until it spills over the top edge of binwalls drained best. Spoilage occurred a few inches below the grain surface, so frequent checking by probing is important.

Grain going into temporary storage must be dry. Aeration cools the grain to enhance storability but is not adequate to remove moisture from grain.



NDSU EXTENSION SERVICE

North Dakota State University, Fargo, ND 58105

AUGUST 1998

Using Existing Buildings

Many types of buildings such as pole buildings used for machinery storage, empty barns, and stud framed shops or garages can be used for grain storage.

Make sure the building location is well drained. If the building does not have a concrete floor, place the grain on plastic to prevent moisture moving from the ground to the grain. Even with a concrete floor, it is advisable to cover the concrete with plastic, especially if the concrete is cracked. Moisture vapor will move through concrete and into the grain if the soil below the concrete is wet.

Most farm buildings are not built to withstand lateral loads other than those normally sustained from wind pressure, so they will need to be strengthened to support grain pressure.

Check with the building manufacturer about safe depth of grain to use in existing commercial buildings.

The pressure grain exerts per foot of depth is called the equivalent fluid density (EFD).

The lateral pressure pushing out at the bottom of a wall is calculated by multiplying the grain depth by the EFD of the grain. The EFD for some types of peaked grain are shown in Table 1. The force per square foot pushing out at the bottom of a 6 foot depth of wheat is 144 pounds per square foot; 24 x 6. The total force pushing on the wall is 432 pounds per linear foot of wall; 144 x 6 / 2. The EFD listed in Table 1 is for peaked grain. The EFD for level filled piles is about 80% of that of peaked grain. A comparison of needed building structural strength for different types of grain can be made by comparing the equivalent fluid density. The grain depth a wall can support is roughly related to the cube root of the ratio of the EFD.

Table 2 lists the safe depth of wheat, rye, shelled corn, grain sorghum, and beans for the stud sizes listed based

Table 1. Approximate equivalent fluid density of some peaked grains.

Crop	Equivalent Fluid Density
	lb/cu. ft
Barley	20
Corn (shelled)	23
Oats	14
Grain Sorghum	22
Soybeans	21
Sunflower (non-oil)	9
Sunflower (oil)	12
Durum wheat	26
HRS wheat	24

Table 2. Safe depth of wheat, rye, shelled corn, grain sorghum and beans for stud sizes listed.¹

Stud Size			Grain Depth (feet) for Stud Spacing		
Nominal	Dressed	Stud Length	24"	16"	12"
----- Inches -----			(feet)		
Old Lumber					
2 x 4	1 5/8 x 3 5/8	8	5	6	7 1/2
2 x 6	1 5/8 x 5 5/8	8	8	8	9
2 x 6	1 5/8 x 5 5/8	10	7	9	9
1982 Lumber					
2 x 4	1 1/2 x 3 1/2	8	4	4	5
2 x 6	1 1/2 x 5 1/2	8	6	7	8
2 x 8	1 1/2 x 7 1/4	8	7	8	8
2 x 10	1 1/2 x 9 1/4	8	8	8	8
2 x 4	1 1/2 x 3 1/2	10	4	4	5
2 x 6	1 1/2 x 5 1/2	10	5	6	7
2 x 8	1 1/2 x 7 1/4	10	7	8	10
2 x 10	1 1/2 x 9 1/4	10	9	10	10
2 x 12	1 1/2 x 11 1/4	10	10	10	10

¹ If large knots occur in any of the studs or if the lumber is soft and lightweight, use cross ties at 0.45 the depth of grain. Studs should be well fastened to the sill and top plates.

on 1982 allowable stress values. The allowable bending stresses for lumber have been decreasing over time, so safe depths for new lumber would be less. For example, the allowable bending stress for #2 Southern Pine was 1,200 psi in 1982 and was reduced to 1,050 psi in 1991, according to the National Forest Products Association Design Values for Wood Construction. The design value for Douglas Fir-Larch was reduced from 1,250 psi to 875 psi. Spruce-Pine-Fir (South) #2 dimension lumber has a design stress value of 750 psi. Grain depths used should be adjusted based on the bending stress of the wood. For example, the allowable bending stress for Southern Pine was reduced from 1,200 in 1982 to 1,050 in 1991, so the depths should be reduced to 88% of the 1982 depth shown in the table; 1050/1200.

The maximum bending force on a grain wall is at approximately 0.5 times the grain depth. Therefore, the optimum location for tying sidewalls together with a cable is at about 0.5 times the depth of grain above the floor.

Pole frame buildings are frequently used for grain storage. The maximum grain pile depth for various size poles in a building built before 1991 is shown in Table 3. The walls should be tied together at the eave by a cable if the truss has not been designed and connected to carry the grain load (Figure 1). To provide support for the poles, cables should be installed at about 0.5 times the grain depth above the floor.

Maximum grain depths for pole buildings built since 1991 are shown in Table 4.

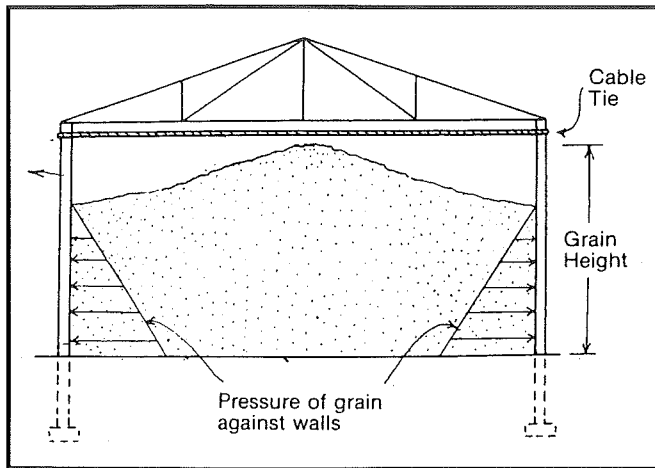

Figure 1. Use a cable to tie post tops together or walls may pull apart from roof. (NRAES-1 Pole and Post Building Construction, 1977.)

Nominal 2 inch (1.5") tongue and groove decking or center matched planks are often used to withstand high lateral pressures at the bottom of bulk storages. Table 5 lists the maximum uniform load for plywood and plank lining with supports spaced at 2, 4, 6 and 8 feet apart. Install plywood sheets or planks long enough to

Table 3. Maximum grain depth supported by Douglas Fir-Larch or Southern Pine posts and poles. Built before 1991.

POSTS	Oats & Sunflower			Corn, Wheat, Rye		
	4	6	8	4	6	8
	----- Post or Pole Spacing, Feet -----					
5.5 x 9.5	—	10.7	9.7	10.3	9.0	8.3
7.5 x 7.5	—	10.1	9.2	9.8	8.6	7.8
6.0 x 8.0	11.2	9.8	8.9	9.5	8.3	7.5
5.5 x 7.5	10.5	9.1	8.3	8.8	7.7	7.0
6.0 x 6.0	9.3	8.1	7.4	7.8	6.9	6.3
3.5 x 7.25	8.7	7.6	7.0	7.5	6.5	5.9
5.5 x 5.5	8.5	7.4	6.7	7.2	6.3	5.7
4.0 x 6.0	8.1	7.1	6.4	6.9	6.0	5.4
3.5 x 5.5	7.3	6.3	5.8	6.2	5.4	5.0
4.0 x 4.0	6.2	5.4	4.9	5.2	4.6	4.1

POLES

Circumference	Diameter						
30	9.5		10.9	10.2	9.3		
28	8.9		11.2	10.2	10.9	9.6	8.6
26	8.3		10.5	9.5	10.1	8.8	8.0
24	7.6	11.0	9.7	8.7	9.4	8.2	7.5
22	7.0	10.1	8.8	8.0	8.6	7.5	6.8
20	6.4	9.2	8.0	7.3	7.8	6.8	6.2
18	5.7	8.3	7.3	6.5	7.0	6.2	5.5

Note: Tie post tops together with properly designed truss or cable to keep walls from pulling apart from the roof. Do not overtighten cable or truss will buckle. Grain depths on the wall can be increased by 8% if the grain is not peaked. Modified from NRAES-1, 1997.

cover at least two spans (3 posts); pieces that only span between two posts may deflect excessively under load. To determine the maximum grain depth that the sheathing can support, divide the maximum uniform load from Table 5 by the equivalent fluid density from Table 1.

Figure 2 (page 4) shows construction details for adding a 4 foot high wall between the posts to contain the grain. One option is to place the framing between the posts. Cut the sill and plate to fit between the posts. Attach the 2 x 6 sill and 2 x 6 plate to the 2 x 4 studs with two 16d nails at each end. Tip the frame into place. Fasten the sills and plates to the posts with framing anchors. Line the wall with 4 x 8 feet, 5/8 or 3/4 inch plywood sheets. Select plywood with a span rating of 42/20 Ext. To keep grain from falling between the grain wall and the building wall, add a baffle from the top of the grain wall to a wall girt.

Another option is to move the new frame inside the posts. The sill and plate can be continuous across one or more posts; add a stud at each post to support the plywood. Anchor the sill to the floor with angle irons and anchor bolts or with anchor nails driven through the sill with a stud gun.

Table 4. Maximum depth of bulk products for selected post sizes and spacings (Southern Pine No. 2). Built since 1991.

Post Size	Corn, Wheat, Rye			Oats & Sunflower		
	4	6	8	4	6	8
----- Post Spacing, feet -----						
4 x 6	4.3	3.8	3.4	5.2	4.5	4.1
6 x 6	5.0	4.4	4.0	6.1	5.2	4.8
6 x 8	6.2	5.4	4.9	7.4	6.5	5.9
6 x 10	7.3	6.3	5.7	8.7	7.6	6.9
8 x 8	6.8	6.0	5.4	8.3	7.2	6.5
8 x 10	8.0	7.0	6.3	9.6	8.5	7.6

Modified from NRAES-1 Post-Frame Building Handbook, 1997.

Table 5. Load-span for selected wood sheathing materials.

Sheathing Material	Maximum uniform load in psf with supports spaced at:			
	2 ft.	4 ft.	6 ft.	8 ft.
3/4" APA Structural I (unsanded, dry) Fb= 2000 psi	183	46	20	11
1 1/8" APA Structural I (unsanded, dry) Fb=2000 psi	388	97	43	24
2 x 10 Spruce-Pine-Fir planks (No. 2) Fb = 875 psi	506	126	56	32
2 x 10 Southern Pine planks (No. 2) Fb = 1051 psi	607	152	67	38

NRAES-1, 1997.

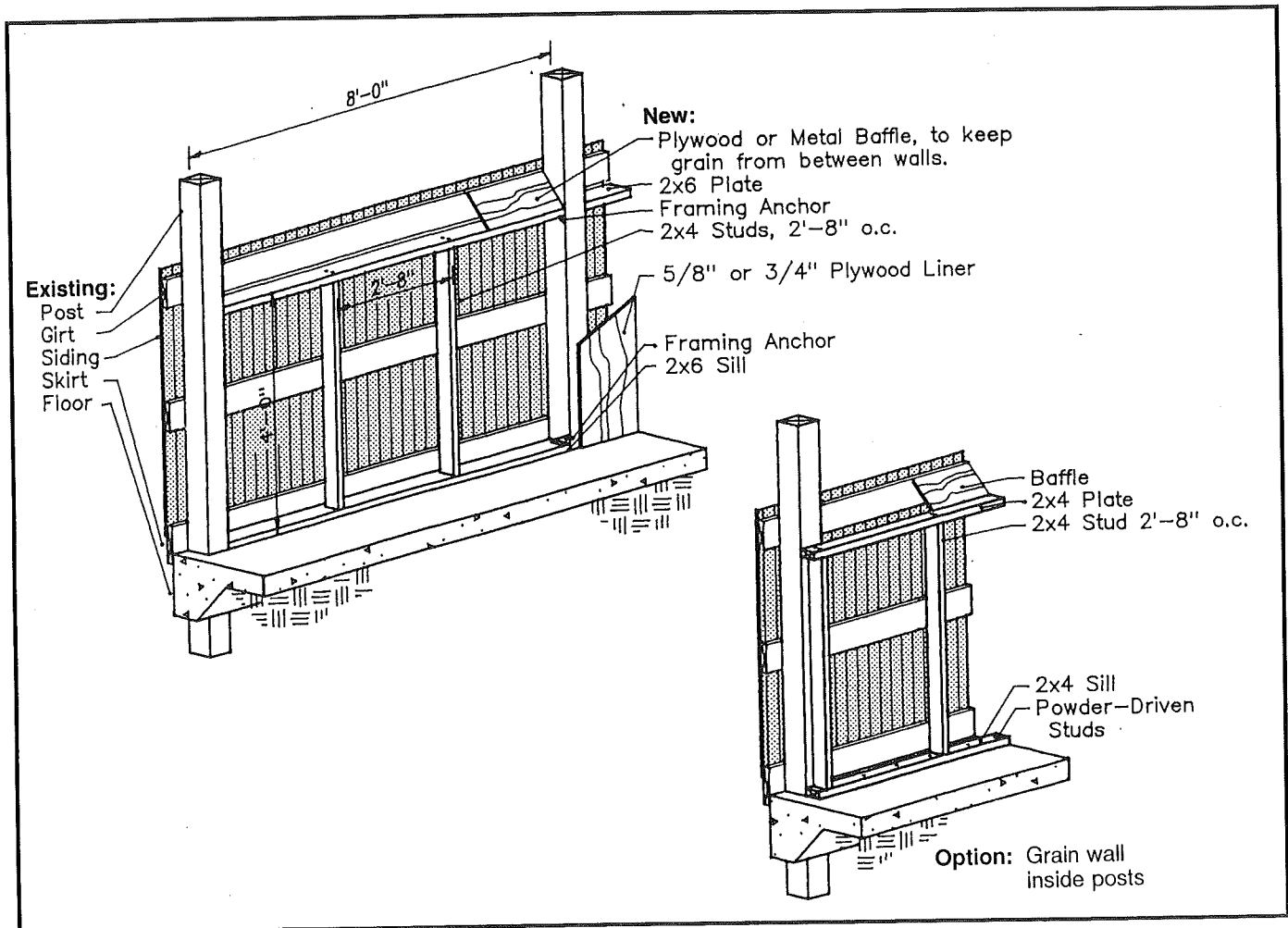

Figure 2. Grain liner for post-frame buildings.

Fasten plate and sill to 2 x 4 studs before installing framing in the wall. Drive two 16d nails through sill and plate into ends of each stud. Studs are flush with inside face of posts. Lumber is No. 2 or better, Southern Pine or equivalent. (MWPS-13 Grain Drying, Handling and Storage Handbook, 1988.)

Separate Bin Walls

Steel bin rings

Round bin rings can be conveniently and economically erected to provide emergency grain storage. Two or three steel rings from round grain bins can be set on an existing floor. Anchor the bin rings as recommended by the manufacturer.

Round plywood bins

Plywood bins, 4 or 8 feet deep and 10-37 feet in diameter, can be made by nailing plywood sheets and 2 x 4 nailers into a long strip and bending to form a circle (Figure 3). Fasteners and nails are critical to keep the bin from bursting.

Use at least 3/8" plywood with at least a 24/0 span rating. The recommended method for fastening plywood sheets together is shown in Figure 4 and Table 6. Usually it is a joint that fails, not the plywood sheet itself. If in doubt about plywood strength, wrap the bin with cable, hoops or at least No. 9 wire.

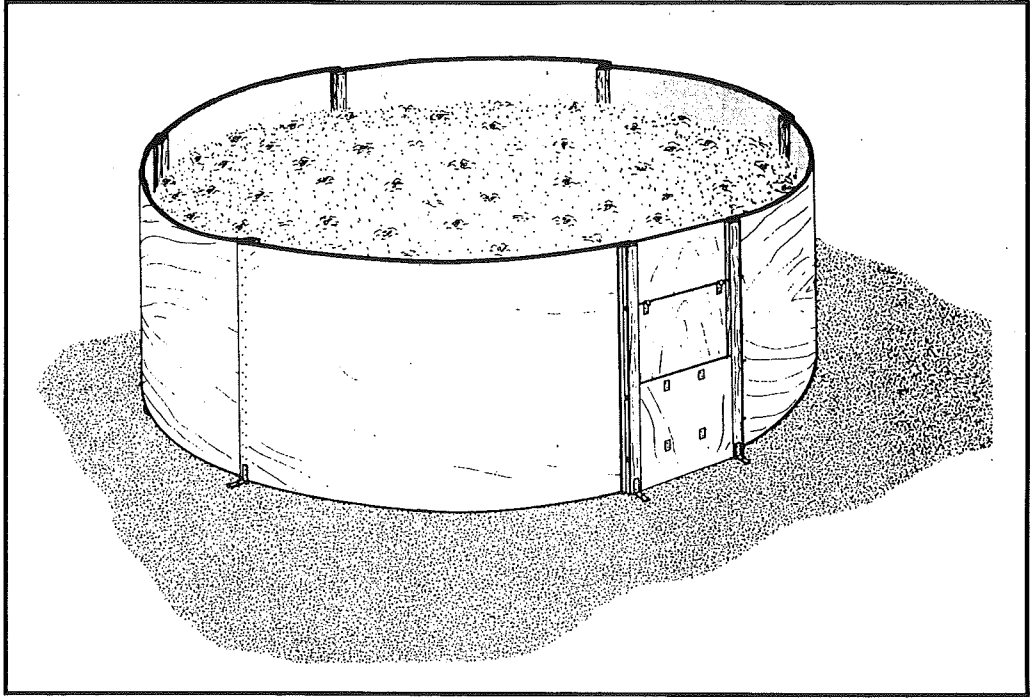

Figure 3.
Round
plywood
bin.

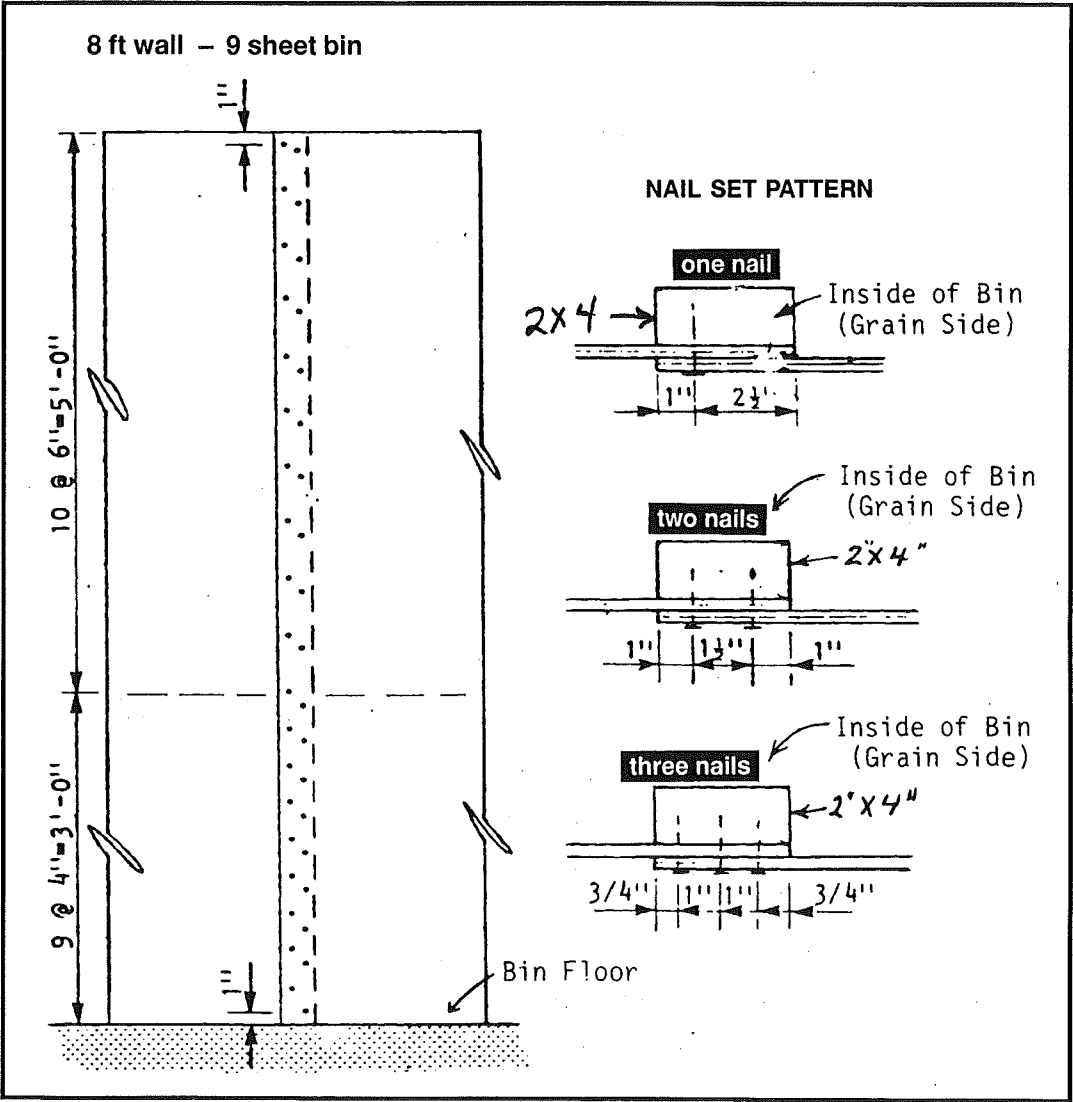

Figure 4.
Nailing schedule for
round plywood bins.

Table 6. Nailing schedule for round plywood bins*.

3/8" 24/0 Plywood	Number of Plywood Sheets									
	9	13	17	4	6	8	10	12	15	
	----- 8' Wall Height -----					----- 4' Wall Height -----				
Bin diameter (ft.)	10.6	15.4	20.1	9.8	14.7	19.6	24.5	29.4	36.8	
Level capacity (bu.)	565	1180	2025	240	540	970	1500	2180	3400	
Peaked capacity (bu.)	625	1350	2125	280	700	1340	2220	3420	5800	
	Nails per Set									
	2	2	3	1	2	3	3	3	3	
Nail set spacing from bottom for 1 1/2" large head gal, roofing nails	9@4" 10@6"	14@3" 3@4" 7@6"	8@3" 6@4" 8@6"	11@4"	9@5"	9@5"	8@3" 6@4"	12@2" 8@3"	12@2" 8@3"	

* Use longer nails for thicker plywood. Canada Plan Service, Plans 8421 and 8422.

Movable wood grain walls

They are built of plywood and lumber, are self-supporting, and can convert all or part of a building to grain storage.

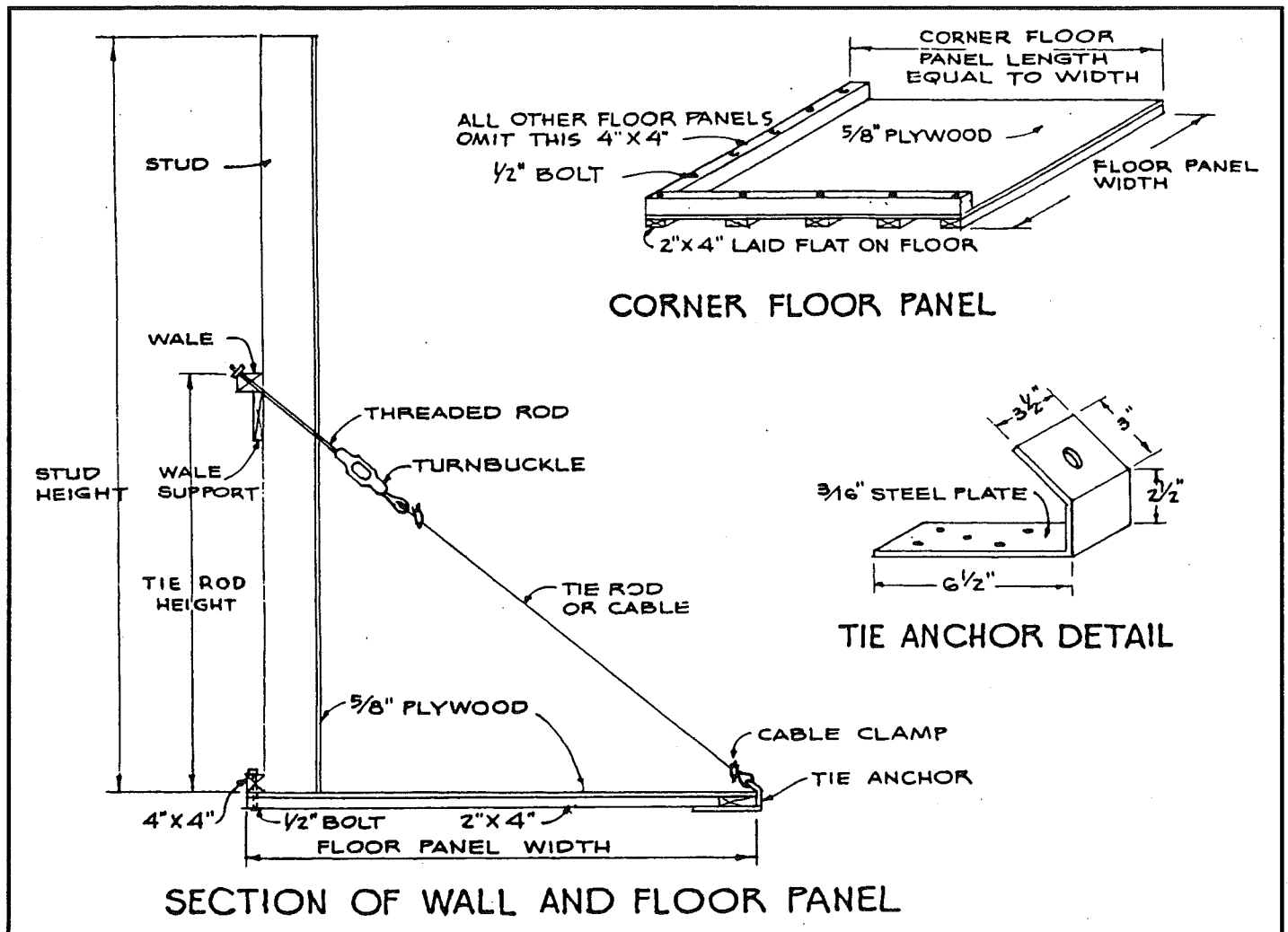

Figure 5. Details of self-supporting portable wall.

For structural adequacy, follow these specs:

1. Lumber grade is No. 2 or equivalent Douglas Fir structural light framing, or joists and planks. Compare the allowable bending stress of the wood.
2. Place the 4 inch edge of the wale next to the stud.
3. Select plywood with a span rating of 42/20 Ext. Or, use 5/8 CDX plywood if of Douglas Fir, Southern Pine, or other group 1 or 2 species. Plywood of Group 3, 4, or 5 species must be 3/4 inch thick.
4. Place face grain of plywood across the supports.
5. Wale supports carry a heavy vertical load from the tie rods. Glue wale supports to studs with a construction adhesive; add two 3/8 inch lag bolts/stud.
6. Ties are 32 inches apart and are sized for heavy wheat. Steel cable or strand, or threaded rods, may be used instead of strap ties. Install thimbles in cable ends. Select turnbuckles, and cable if used, for adequate strength.

Table 7. Member sizes for portable bulkheads.

Height	Stud Size	Spacing	Tie Rod			Wale Size	Wale Support Size	Floor Panel Width	Sleeper Size	Sleeper Spacing
			Height	Minimum Strength	Rod Dia.					
ft.			ft	lb	in.			ft.		
6	2 x 4	16" o.c.	3' 4"	1,300	3/8	4 x 4	2 x 6	6	2 x 4	16" o.c.
8	2 x 6	16" o.c.	4' 4"	2,500	1/2	4 x 6	2 x 6	6	2 x 4	16" o.c.

Shown in Figure 6 (below) are other grain walls that have been used.

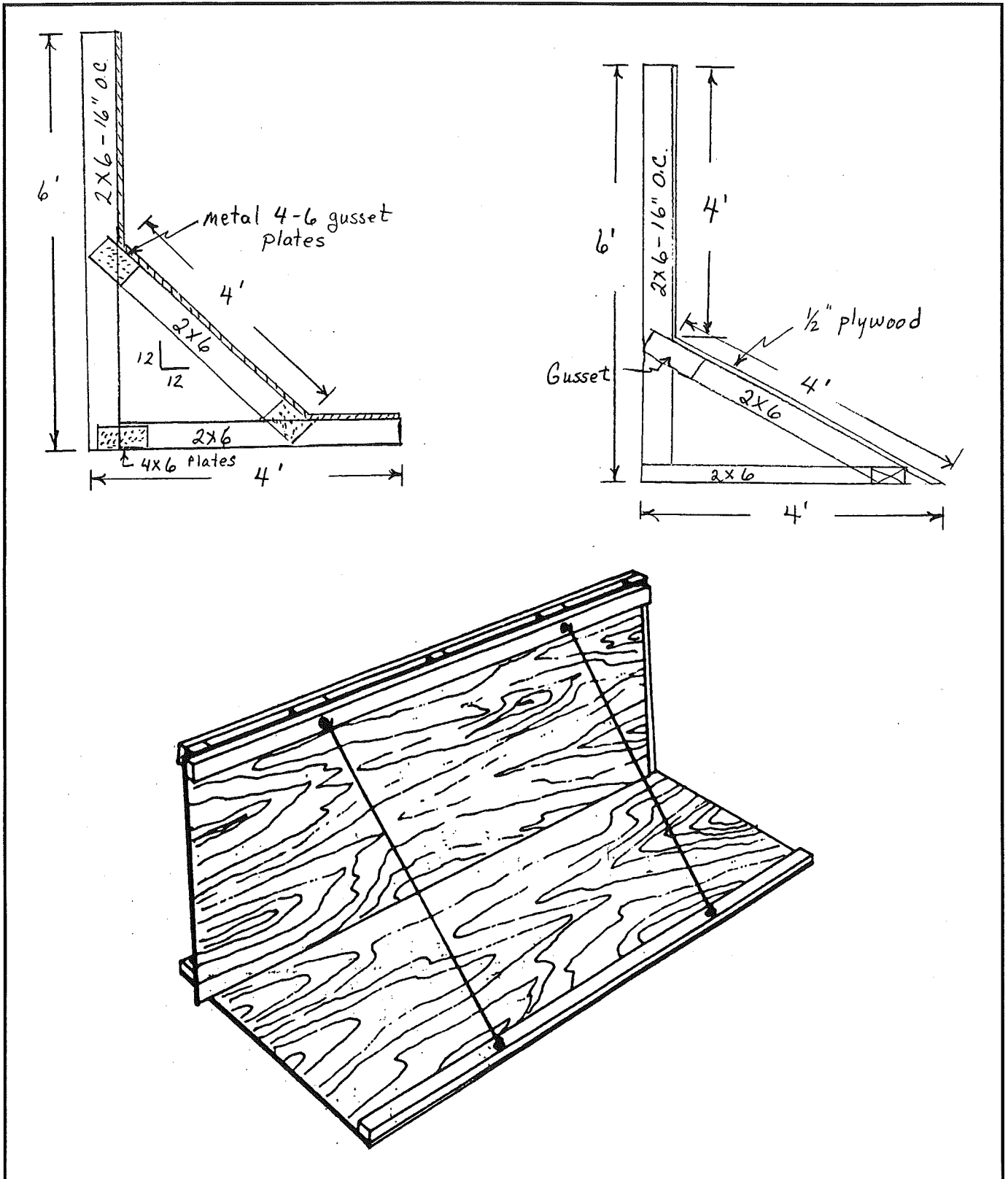

Silos

Concrete silos generally need to be reinforced and weather proofed to hold grain. Table 8 shows suggested hoop spacing for concrete stave silos. Check construction recommendations with silo manufacturer as newer silos use stronger materials. A weather tight roof and chute plus foundation drainage are essential.

An aeration system should be installed to cool the grain and prevent moisture migration. Provide about 1 square foot of vent in the roof for each 1,000 cfm of airflow. Conventional silage blowers should not be used to fill the silo because they cause too much grain damage. Silos must be unloaded from the center to avoid structural damage.

Table 8. Size and spacing of hoop reinforcing rods for concrete stave bins for dry grain.*

Distance From Top in Feet	Diameter of Bin					
	10, 12, 14 ft	16 ft	18 ft	20 ft	35 ft	30 ft
	----- 5/8" dia. -----					11/16" dia.
0-10	15"	15"	15"	15"	15"	15"
10-15	15	15	15	15	15	10
15-20	15	15	10	10	10	10
						3/4" dia.
20-25	15	15	10	10	10	10
						11/16" dia.
25-30	15	10	10	10"	10"	10"
30-35	15	10	10	7½"	10"	7½"
35-40	15	10	10	7½"	7½"	7½"
40-45	15	10	10	7½"	7½"	7½"
45-50	15	10	10	7½"	7½"	7½"

*From MWPS-13 (1974) "Planning Grain-Feed Handling." Information for these older grades are not applicable to modern grades of hi-tensile steel.

Commercially Available Temporary Grain Storage

Units are available through some farm supply stores and grain equipment suppliers. These units vary in construction. Polyethylene sheeting, reinforced-fiber sheeting, wire mesh, wood or metal panels for holding the grain are usually used. Repairs, freight, erection, and site costs need to be included when getting estimates. Some units are reusable.

Various forms of plastic sheeting are available to be used with grain piled on the ground to prevent rain and wind loss. Usually the covering will need repair or replacement after one season of use. Rodents, birds, chewing insects, sharp hooves or claws, gunshot, etc. can cause leak problems. Some suppliers have a mesh or fishnet type of fabric draped over the plastic covering to help hold the plastic sheeting in place. (Suppliers include Raven Industries, Sioux Falls, SD 605/336-2750 and LeMar Industries Corp., Des Moines, IA 515/266-7264.)

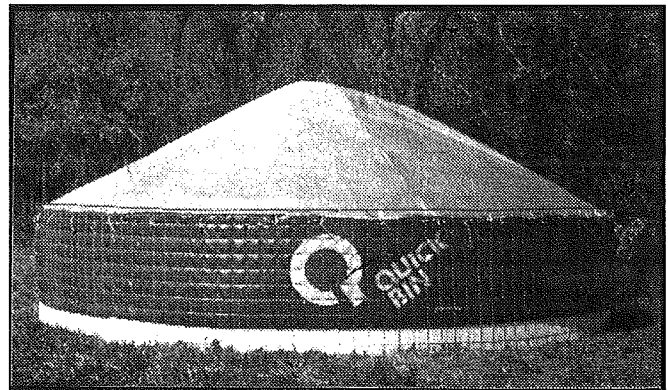

Figure 7. Sidewalls on this type of storage are reinforced with wire mesh and used to support walls 4 feet to 6 feet high. Covers can be reinforced plastic sheeting. Bins are filled with augers. (Suppliers of this type include: B & W Mfg Co., Columbus, NE 402/564-3032 and Thompsons, Melita, Manitoba 204/522-3241.)



Figure 8. Round tubes of plastic about 8 feet in diameter have been developed for silage storage. Limited experience with these for dry grain storage has been satisfactory. Consult with manufacturers for their up-to-date experience. Special filling equipment or technique will be needed.

Suppliers include:

Ag-Bag International, Warrington, OR
(800) 334-7432

Kelly Ryan Equipment Co., Blaire, NB
(402) 426-2151

Sioux Automation Center, Sioux Center, IA
(712) 722-1488

Versa Corporation, Astoria, OR
(800) 837-7288

Bins Formed Using Bales

Large round bales can be used to form a circular bin wall. With a 5-foot grain wall depth, there is a force of about 115 pounds of force on each foot at the bottom pushing the bale outward, so they will likely need to be restrained by wrapping with a cable. Plastic along the inside of the bales is recommended to help keep grain from leaking out and to prevent water from entering. Peak the grain so it flows onto the top of the bales to form a smooth top. The plastic or tarp should drape over the top of the bales, so the water flows to the outside of the bales.

Outside Piles

If you must pile the grain outside on the ground, drainage is crucial. The pile should be on high ground and the earth crowned under the pile. Place plastic (6 mil) on the ground to keep ground moisture from wetting the grain.

Plastic or tarp covering the pile will reduce wetting by rain and snow and minimize damage by wind and birds.

The top surface should be smooth to aid in drainage. The cover should carry the water away from the piled grain to prevent wetting the grain. Condensation under the plastic may cause problems unless it is controlled with aeration. Move airflow under the plastic to carry the moisture away. Drainage tile under the plastic has been used as an air intake duct when the aeration fan exhausts air from the bottom of the pile. The ability to cool the grain by aeration improves the storability of the grain. Run the pile north and south to allow the sun to dry off the sloping sides.

Erect a fence to keep animals off the pile. Nearby trees aid wind protection but can also be a home for birds and might result in snow drifting on the pile.

Storage Capacity

The quantity of grain in piles can be estimated using Table 9. Formulas for calculating the volume of common shapes are shown in Figure 9.

Average filling angles for some types of grain are shown in Table 10.

Table 9. Approximate capacities of unconstrained grain piles.

h Pile Height	d Pile Diameter	Total Bushels	Bushels per Additional 1 ft. of Pile Length
(ft)	(ft)		
3	12.9	105	15
4	17.2	250	28
5	21.5	480	43
6	25.7	840	62
7	30.0	1,330	85
8	34.3	1,980	110
9	38.6	2,820	140
10	42.9	3,870	170
11	47.2	5,150	210
12	51.5	6,700	250
13	55.8	8,500	290
14	60.0	10,600	340
15	64.3	13,000	390
16	68.6	15,900	440
17	72.9	19,000	500
18	77.2	22,500	560
19	81.5	26,500	620
20	85.8	31,000	690

$$d = 2 \times (h/0.4773) \text{ approximate}$$

$$h = 0.233 d \text{ approximate}$$

$$d = \text{circumference}/3.14$$

$$\text{pile bushels} = 0.21045 \times d \times d \times h$$

$$\text{additional bushels/ft} = 0.402 \times d \times h$$

$$1 \text{ bushel} = 1.244 \text{ ft}^3$$

Based on 25° grain filling angle. Grain angle will vary depending on grain moisture content, foreign material, piling method and type of grain.

Table 10. Average filling angle of some grains.

Crop	Average Filling Angle
	(degrees)
Barley	28
Corn (shelled)	23
Oats	28
Grain Sorghum	29
Soybeans	25
Sunflower (non-oil)	28
Sunflower (oil)	27
Durum wheat	23
HRS wheat	25

Management of Temporary Grain Storage is Extremely Important

Check frequently for heating, sweating, moisture accumulation and general condition of grain and the bin. Exposed grain pile tops get trampled on, windblown and damaged by moisture. Temporary plastic coverings are loosened by temperature changes, changing winds, ice, animals and vandalism. Walls can suddenly burst open from extra pressure caused by wetted grain. Hoops, bands or other types of wall reinforcement can fail.

Cooling the grain with aeration is vital for proper storage. Cool temperatures minimize mold growth, limit moisture migration, and control insects. An aeration air-flow rate of about 1/10 to 1/5 cubic feet per minute per bushel is recommended for dry grain.

Operate aeration fans until piled grain temperatures are uniform and equal to the average outdoor temperature or near freezing.

Temporary grain storage is for less than 6 months. Grain should be moved to permanent storage before warm spring weather that can aggravate the poorer, temporary storage conditions. Stored grain is the result of a season's work — it deserves as much attention in storage as it took to produce it in the first place.

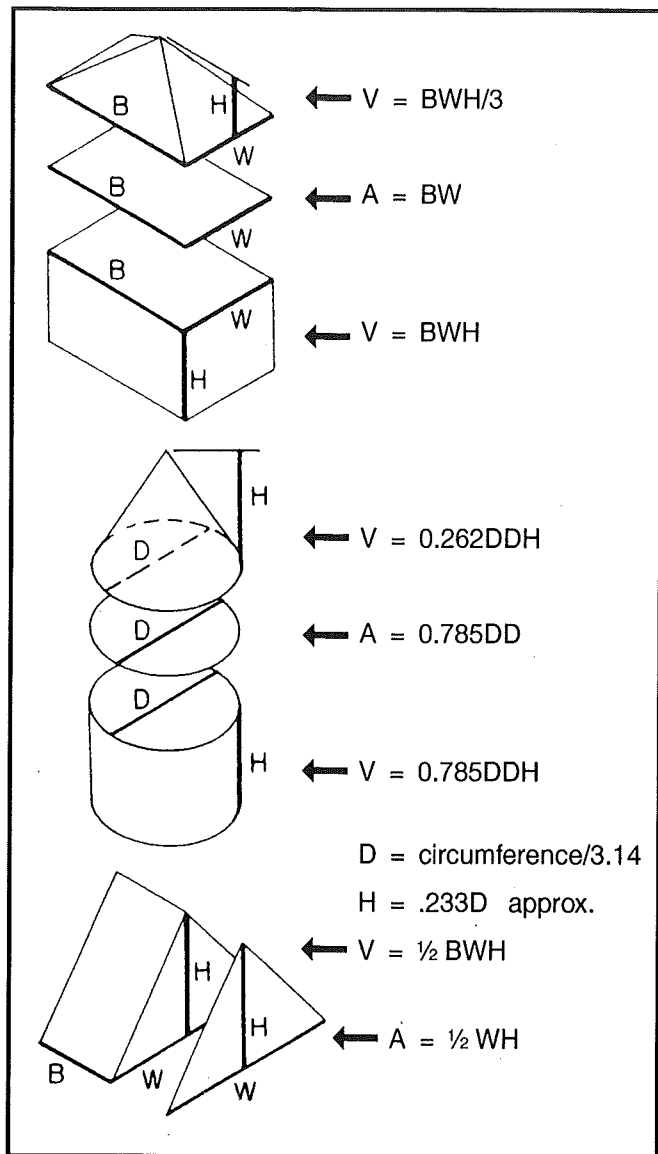

Figure 9. Areas and volumes. MWP-13, 1988.
1.244 ft³/bu.

The mention of specific companies here is not an endorsement.

This is done for illustrative purposes and reader convenience.

Omissions were not intended and additional information is welcome.



AE84

NDSU Extension Service, North Dakota State University of Agriculture and Applied Science, and U.S. Department of Agriculture cooperating. Sharon D. Anderson, Director, Fargo, North Dakota. Distributed in furtherance of the Acts of Congress of May 8 and June 30, 1914. We offer our programs and facilities to all persons regardless of race, color, national origin, religion, sex, disability, age, Vietnam era veterans status, or sexual orientation; and are an equal opportunity employer.

??-8-98

This publication will be made available in alternative formats for people with disabilities upon request, 701/231-7881.