

GBH092
(Revised)

North Dakota 4-H Horse Show Rules and Judging Guide



NDSU EXTENSION
SERVICE

May 2012

This book belongs to

Name _____

Address _____

County _____

Telephone Number _____



North Dakota 4-H Horse Show Rules and Judging Guide

Compiled and revised by the
NDSU Extension Service state equine
specialist, staff from the NDSU
Equine Studies Program and the
North Dakota 4-H Horse Advisory
Committee.

Acknowledgments:

Information was compiled from NDSU 4-H horsemanship publications, the American Quarter Horse Association, U.S. Equestrian Federation, Indiana Cooperative Extension Service, Nebraska Cooperative Extension Service, Minnesota Cooperative Extension Service and South Dakota Cooperative Extension Service.

This manual is intended as a guide for 4-H leaders, Extension agents, show managers and other individuals planning and conducting 4-H horse shows in North Dakota, and for youth to learn about horse shows. The manual will help establish uniform regulations and procedures in 4-H horse shows and events throughout North Dakota. Use it as a guide to learn about horse shows, setting up classes, establishing show rules and general show management. Guidelines such as age divisions are established for the North Dakota State Fair and may be adjusted to fit the situation at county 4-H horse shows. Words that are included in the glossary are printed in *bold, italic letters* the first time they appear in the text.

Contents

4-H Horsemanship Project	6
4-H Membership	7
Horse Ownership and Training	7
General Horse Show Rules	8
Tack and Attire	9
Showmanship	17
Class Requirements.....	17
Appearance of Horse.....	18
Appearance of Exhibitor	18
Showing Horse in Ring	18
Western Class Routines	23
Western Horsemanship.....	23
Reining	27
Trail	38
Western Riding	44
Western Pleasure	51
Ranch Horse Pleasure	55
English Class Routines	60
Hunt Seat Equitation	60
Equitation Overs Fences.....	65
Hunter Hack	69
Hunter Under Saddle.....	72
Timed Riding Classes	76
Pole Bending	76
Barrel Racing	79
Goat Tying	82
Keyhole	86

Horse Show Operation and Judging Guide	89
Use of 4-H Name and Emblem	89
General Horse Show Management Considerations	90
Judging 4-H Horse Shows	91
Danish Judging System.....	91
Guidelines for Horse Show Judges	92
 Glossary of Terms	 93

4-H Horsemanship Project

The main objective of the 4-H Horsemanship project is to learn how to care for a horse. Horsemanship includes feeding, grooming, stable management, health maintenance, disease prevention, and care and maintenance of tack. Leaders and project helpers work with youth to emphasize all parts of horsemanship. Participants can exhibit their projects on the county level and at local or state horse shows.

Project Goals

1. Learn about leadership and sportsmanship.
2. Develop responsibility, initiative and self-reliance.
3. Take pride in owning a horse or pony and be responsible for its management.
4. Develop an appreciation of horseback riding as a form of recreation.
5. Learn and practice skills in horsemanship.
6. Understand the business of breeding, raising and training horses.
7. Know safety precautions to prevent injury to riders and others.
8. Learn to love and respect animals and develop a humane attitude toward them.

The guiding principles of the 4-H Horsemanship Project are to promote horsemanship, safety and education.

4-H Membership

Any individual who is 8 years old by Sept. 1 is eligible to join a 4-H club. Any participant who becomes 19 before Sept. 1 is not eligible for 4-H membership or participation.

Class/age divisions are as follows:

8-11 Junior

12-14 Intermediate

15-18 Senior

Age requirements are flexible for special circumstances involving youth or adults who have learning disabilities or other special needs.

Horse Ownership and Training

1. All light horses, ponies and mules are eligible for a project. Height classifications may be a division point between classes.
2. Members must have managing control of their horse project. "Managing control" means overseeing proper feeding, grooming, exercising, training and stall management, and the member must have free access to the use of the horse at all times.
3. A family-owned or joint-ownership horse may be managed jointly by members. However, a horse may be exhibited only once in any lot (each age division is a separate lot). Once a horse has been exhibited, it cannot be exhibited again in the same class/lot during the show.
4. A 4-H member enrolled in the 4-H Horsemanship project must have managing control of the horse by **May 1**. The horse may be owned, rented, leased or borrowed for use as a 4-H project. If the horse is not owned, the legal owner must provide a written statement guaranteeing that the 4-H member has managing control of the animal by **May 1**. This statement is kept on file in the county Extension office in the county of enrollment.
5. A 4-H member may exhibit up to two horses for his/her 4-H Horsemanship project. (Yearling to Maturity and Ranch Horse project horses are in addition to the "two-horse" limit.)
6. Exhibitors must receive a blue ribbon at a qualifying county 4-H show in each event they wish to participate in at the State Fair 4-H Horse Show.

General Horse Show Rules

1. Rules in this manual will have precedence over all other rules. American Quarter Horse Association (AQHA) rules will be used for any rules not covered in this manual. Rulebooks are available on the AQHA Web site: www.aqha.com.
2. An exhibitor engaging in unsportsmanlike conduct will be dismissed from the class.
3. **Drugs and medications:** The international Association of Fairs and Expositions (IAFE) national code of showing ethics will be followed by all horse exhibitors at the North Dakota State Fair. This code includes the following statement: **At any time after an animal arrives on the State Fair premises, all treatments involving the use of drugs and/or medications shall be administered by a licensed veterinarian.**
4. The exhibitor is responsible for errors on the entry blanks. A horse entered in the wrong class may be transferred to its correct class prior to the start of the event.
5. Any unnecessary whipping, jerking of the reins, talking, noise making, slapping or any other action will be considered a fault and scored accordingly.
6. Only mares and geldings may be shown (weanling stud colts allowed).
7. Horses, ponies and mules exhibiting in Western classes will be shown under Western saddle. Showmanship at Halter may be shown in either English or Western attire or tack.
8. Age of the horse is computed by calendar year starting Jan. 1 of the year foaled. For example, if a horse is foaled in 2005, it becomes a yearling as of Jan. 1, 2006.
9. Tails may be lengthened by hair-to-hair attachment. Alteration of tail movement by any means (surgical, chemical, etc.) is prohibited.
10. Exhibitor numbers must be clearly visible. If worn on the back of the exhibitor, the number must be pinned on the top and bottom. If displayed on the saddle pad, a number must be on each side.
11. For all pattern classes, patterns should be posted a minimum of one hour prior to the start of the class.
12. For Equitation Over Fences and Hunter Hack, contestants should be allowed a practice jump either in the warmup area or prior to the start of the class.

13. Unruly horses will be dismissed at judges' or show management discretion.

14. Exhibitors should be prepared and waiting at the gate for the start of their class. Three calls will be made and the gate will be closed. Once the gate is closed, exhibitors will not be allowed to enter.

Tack and Attire

Exhibitors and judges should bear in mind that all entries are being judged on ability and performance, **not** on personal appearance. However, judges must penalize participants who do not conform to the tack and attire rules of 4-H. This includes, but is not limited to, dress code, helmet rule and legal equipment described for all classes. Participants not conforming to the dress code outlined below will be dismissed from the class.

All tack needs to be clean, neat, in good repair and properly adjusted. Tack that is considered to be legal for the various 4-H events and rules on proper 4-H apparel follows below.

Showmanship at Halter

1. Horses may be shown with either Western or English tack or attire. A clean-fitting halter with an appropriate lead is required.
 - a. Western: horse should be shown with a halter and lead shank. Chains under the chin are permitted.
 - b. English: horse should be shown with either a halter and lead shank or a bridle and reins.
2. Western hats may be substituted for a helmet in showmanship classes only.

Western

Performance Tack

1. Silver or fancy equipment shall not count over good working equipment.
2. Horses shall be shown with a stock saddle.
3. Whenever this manual refers to a **curb** bit in Western performance classes, it means use of a curb bit that has a solid or broken mouthpiece, has shanks and acts with leverage. All curb bits must be free of mechanical devices and are considered a standard Western bit. Shanks, fixed or loose, are to be 8½ inches maximum in length. Mouthpiece bars must be round, oval or egg-shaped, smooth and unwrapped metal. They

may be inlaid but must be smooth or latex-wrapped. Nothing may protrude below the mouthpiece (bar), such as extensions or prongs on solid mouthpieces. The mouthpiece may be two or three pieces. The *port* must not exceed 3½ inches, with rollers and covers acceptable, and diameter 5/16 inch to 3/4 inch. See Figure 1 for measurements.

4. When a curb bit is used (regardless of the age of the horse), only one hand is permitted on the reins (see Figure 6).
5. When a curb bit is used, a curb strap or chain is required (see Figure 2).
6. Bosals or nosebands are not permitted with a bit.
7. A tom thumb snaffle bit is considered to be a curb bit and, therefore, any horse being shown in this bit must be ridden one-handed.
8. Curb chain/strap must be a minimum of 1/2 inch wide and lie flat against the jaw. Curb chain/strap may be leather, double-linked flat chain or extrawide flat hunter-type single link chain. No other metal/wire is permitted under the jaw, regardless of how padded. Legal curb chains/straps are shown in Figure 2.
9. Whenever this book refers to a *snaffle* bit in Western performance classes, it means the use of a smooth snaffle bit (no shanks) with a broken mouthpiece of

Figure 1. Legal Bit

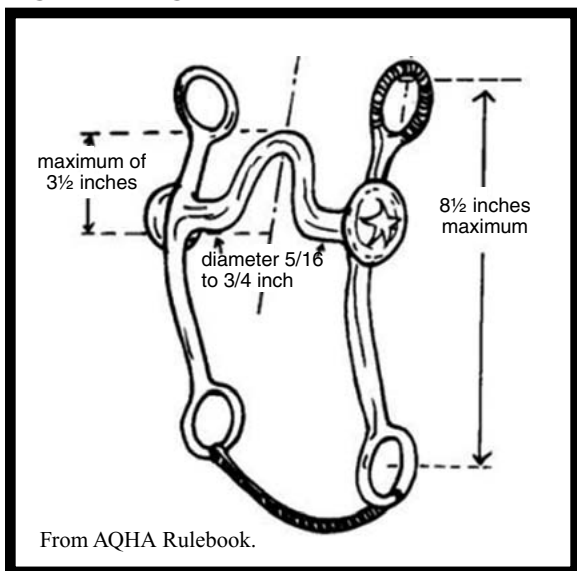
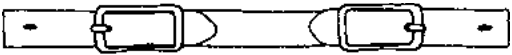

Figure 2. North Dakota Curb Straps

LEGAL



LEGAL — Flat leather - more than 1/2" wide



LEGAL — Flat nylon - more than 1/2" wide



LEGAL — Double link flat chain - more than 1/2" wide nylon end straps



LEGAL — Double link flat chain - more than 1/2" wide leather end straps



LEGAL — Double welded chain links - more than 1/2" wide



LEGAL — Very wide flattened chain links - hunt and polo

NOT LEGAL —

In Pleasure, Horsemanship and Reining



NOT LEGAL — Single link chain - wide enough but too rough



NOT LEGAL — Round leather - too narrow at chin, not flat



NOT LEGAL — Round leather - too narrow all across, not flat

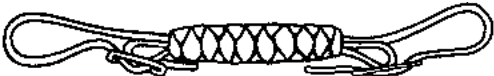

NOT LEGAL — Round braided leather - wide enough, but rough and not flat



NOT LEGAL — Braided leather (rawhide) - too narrow and too rough

at least 3/8-inch diameter, which may have D-ring, O-ring or eggbutt cheek pieces. A loose chin strap of leather or nylon must be attached below the reins. Split reins must be used, with two hands on the reins. See illustration of acceptable snaffle bits and hand positions in Figure 3.

- Whenever this manual refers to *bosals*/rawhide or leather *hackamores* (excluding mechanical

Figure 3. Acceptable Snaffle Bits and Hand Positions

Typical examples of acceptable bits or bosal

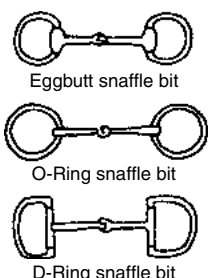

Eggbutt snaffle bit

O-Ring snaffle bit

D-Ring snaffle bit



Hackamore (Rawhide bosal)
A bosal may also be used on Jr. horses, except snaffle bit 2-year-olds.

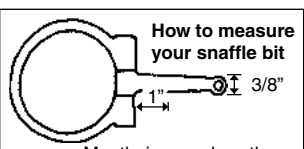

How to measure your snaffle bit

1" 3/8"

Mouthpiece no less than 3/8" measured 1" from the cheek, constructed from smooth round material

Hand and rein positions when riding two-handed.



These hand positions should be severely penalized.



Acceptable hand positions.

hackamores) in Western performance classes, it means the use of a flexible, braided rawhide or leather bosal, the core of which may be either rawhide or flexible cable. Absolutely no rigid material will be permitted under the jaws regardless of how padded or covered. A minimum of one finger space must be between the bosal and animal's nose. Bosals must be used with two hands on the reins. See illustration of bosal and acceptable hand position in Figure 3. This description **does not** refer to a mechanical hackamore.

11. **Junior horses** are 5 years old or younger and **senior horses** are 6 years old or older.
 - a. Junior horses (5 years old or younger) may be shown in a snaffle bit, bosal, curb bit, half-breed or spade bit.
 - b. Senior horses (6 years old and older) may be shown **only** in a curb bit, half-breed or spade bit with one hand on the reins.
12. Split reins or closed, braided reins (a **romal**) are required in Western classes. (**Exceptions: Timed events or when riding a junior horse with a snaffle bit or bosal.**) Reins are to be held in one hand and not to be changed except in Trail, when changing hands is permissible when negotiating an obstacle, such as the gate. Split reins must fall on the same side as rein hand. Hand is to be around reins. Only one finger is permitted between split reins.
13. Fingers between reins are not permitted when using a romal. Romals should be held in the free hand, with approximately 16 inches between the reining hand and free hand holding the romal. The romal shall not be used forward of the cinch or used to signal or cue the horse in any way.
14. In **Horsemanship, Western Riding, Reining or Trail classes**, hackamore bits, gag bits, unorthodox or severe mouthpieces or pressure headstalls are not permitted.
15. **In timed events (barrel racing, pole bending) only**, mechanical hackamore and gag bits are permitted in addition to those listed previously and, if used, must have enough play to permit two fingers to pass between the chin and curb strap/chain. Closed braided reins may be used with any type of bit or hackamore. Tie-downs and martingales are permitted. Bats can be used.
16. Spurs are permissible but must be dull and rowels free-moving. Blunt rowels are permissible.
17. Protective boots will be allowed in Western Riding, Reining, timed events and Equitation Over Fences.

Western Attire

1. Western hat may be worn for showmanship.
2. Protective head gear is required (ASTM approved equestrian helmet) in all mounted events. If you do not wear a helmet, you will not be permitted to participate. Helmets must be fastened when mounted.
3. Shirts and blouses must be long-sleeved, solid white with a collar.
4. Dark blue denim or black jeans (or pants) must be worn and a belt is required.
5. Hard-soled boots with less than a 1/8-inch tread are required.
6. The 4-H emblem must be worn on the front of the shirt.
7. Spurs are allowed, but must be dull, blunt or have a free-moving rowel.

Prohibited

Chaps, spurs in showmanship

Special Note

Additional optional and prohibited attire and/or equipment pertaining to specific classes are noted in the rules for that class.

English

Performance Tack

1. English saddles of the forward or *hunt seat* type are required. Knee inserts on the skirt are optional.
2. Regulation snaffles (no shank), *kimberwicks*, *pelhams* and *full bridles* (with two reins), all with *cavesson* nose bands, are required.
3. In reference to the mouthpiece, nothing may protrude below the mouthpiece (bar). Solid and broken mouthpieces can be used and may not have a port higher than 1½ inches. All mouthpieces must be a minimum of 5/16 inch diameter with snaffles measured 1 inch from the cheek or ring. Smooth ring, slow twist, corkscrew, single twisted wire, double twisted wire and straight bar or solid mouthpieces are allowed. Snaffle rings may be no larger than 4 inches in diameter. Bits of any style (Pelham, snaffle, kimberwick) featuring mouthpieces with cathedrals, donuts, prongs, rough edges or sharp material will be cause for elimination.
4. If a curb bit is used, the chain must be at least ½ inch in width and lie flat against the jaw of the horse.

Optional

Breastplates, braiding mane and tail in hunt style, martingales in Equitation Over Fences

Prohibited

Tie-downs, martingales in flat classes, hackamores, draw reins, protective boots (except in Equitation Over Fences)

English Attire

1. Conservative-colored coat, *breeches* or jodhpurs and boots appropriate for Hunter classes
 - a. At the discretion of the show management, coats may be optional.
2. Colored shirts are permissible in English classes.
3. Conservative-colored ASTM helmet with harness securely fastened must be worn when mounted.
4. 4-H emblem on front left of jacket

Optional

Gloves, spurs (unroweled), crops or bats

Prohibited

Roweled spurs

Special Note

Additional optional and prohibited attire and/or equipment pertaining to specific classes are noted in the rules for that class.

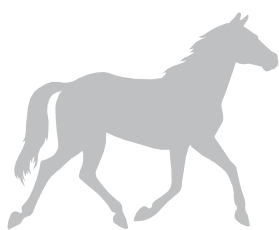

Showmanship

Description

Showmanship is judged on how effective the 4-H participant presents a well-groomed, willing animal and the accuracy through which the team (horse and handler) presents a pattern to the judge.

Class Routine

Class routines may vary, depending on the number of exhibitors and preferences of the judge. In one routine, all exhibitors may be brought into the arena at the same time, asked to line up and then worked individually. A second routine is for each exhibitor to perform the pattern individually as he or she enters the arena. Exhibitors then may be asked to remain in the arena for final placing or may be excused. With either routine, finalists may be asked back for an additional workout to determine the final placing. Regardless of the routine, each showman will complete an individual pattern posted by the show official. Basic maneuvers that may be included in the pattern are walking, trotting, backing, turning, stopping, setting up and presentation for inspection.

Small infractions should not be cause for disqualification of a showman, but may affect his/her overall standing in the class. Conformation of the horse is not judged in showmanship class.

Tack and Attire

Refer to the sections on Showmanship at Halter, Western Attire and English Attire on pages 9 to 16.

General Regulations

1. Only mares and geldings (weanling stud colts are allowed) are eligible.
2. All breeds are shown together and have the option to show according to their breed standard.
3. The ideal time to schedule showmanship classes is at the beginning of the show, prior to any riding classes.

Scoring

A. Appearance of Horse - 20 percent

1. Condition and thriftiness
 - a. Horse is of correct body condition – not overly thin or obese.
 - b. Healthy appearance – no evidence of parasite infestation.
2. Grooming
 - a. Hair coat clean, well brushed.
 - b. Mane and tail groomed for a neat appearance according to breed standard.
 - c. Manes may be banded.
 - d. Hooves trimmed properly. If shod, shoes must fit correctly and clinches need to be neat.
3. Trimming
 - a. Clip the inside of ears; however, horses that are simply “cupped” to allow for protection against insects during the summer months should not be penalized.
 - b. Clip long whiskers around muzzle and eye and under chin.
 - c. Clip long hairs from legs and pasterns. Draft breeds with long feathering on the legs do not need to be clipped.
4. Tack needs to be clean, neat, in good repair and properly adjusted.

B. Appearance of Exhibitor - 20 percent

1. Clothes and person are neat and clean.
2. Compliance with dress code. Spurs are not permitted.
3. Exhibitor is respectful of the judge and fellow showmen.
4. Recognizes and corrects faults in a quick and professional manner.
5. Is able to answer questions asked by the judge.

C. Showing Horse in Ring - 60 percent

Leading and posing

1. Exhibitor leads from the horse’s left side holding lead strap or reins in right hand. If using a lead strap with a chain attached, the length of chain should be adjusted so that the exhibitor is not holding onto the chain. Excess lead strap or reins should be folded or loosely coiled in the left hand. Hand position on the lead normally remains the same when posing as when leading. At no time should the exhibitor change hands on the lead.

2. Train your horse to walk and trot out at the same rate as you do. The horse should lead readily at a walk or trot. The exhibitor's body should be even with the horse's throat latch. Hold your lead arm so that the horse's head and neck are in a direct line with the spine and line of travel. Do not get in front or try to pull the horse into a trot. Keep movement at both gaits brisk and sharp, as opposed to slow and dull.
3. When leading to or from a judge or ring steward, stops and turns are very important. Always allow plenty of space between the horse and judge. Execute stops squarely and without hesitation.
4. Always execute turns of greater than 90 degrees to the right. Turning to the right allows the right hind foot to be used as the pivot point, allowing for a uniform, smooth turn. This results in the horse remaining in essentially the same tracks after the turn, providing the judge a good view as the horse tracks away.
5. Class routines often require walking or trotting out of and back into the lineup of horses. Upon returning, the exhibitor leads all the way through the line, stops, reverses to the right and then leads back into the line to set up.
6. Keep your proper position in line and allow a safe, reasonable space between your horse and the horses on either side. If asked to change positions in the line, back your horse out of the line and approach the new position from behind. If the judge requests you to line up head to tail with other horses, do not crowd the horse in front of you (allow at least one horse's length between you and the horse in front of you).
7. Exhibitors should be aware of their horse's and judge's position at all times.
8. Exhibitors are being judged from the time they enter the ring until dismissed by the judge or ring steward.

Posing and Presentation

1. Horse is posed with feet placed and balanced according to its type and use.
2. Exhibitor keeps whereabouts of judge in mind and has horse alert and in position when judge looks at the horse.
3. Exhibitor does most of the showing with the lead strap. Use of exhibitor's hands or feet to touch or position the horse is *prohibited*.
4. Horse is kept from contact with a competitor or encroachment of space rightfully belonging to another exhibitor.
5. Once set up, present the horse in a way that does not distract the judge's attention from the horse.

Quarters System

Remember that the primary objective is to show the horse. The judge needs a clear, unobstructed view of the animal at all times. The exhibitor must be in a position that enables him/her to watch both the judge and the horse at all times. The method of presentation preferred by most judges for youth exhibitors is the *quarters system*.

In the quarters system, the horse is divided into four equal parts as seen in Figure 4. (Note: quadrants will be labeled A, B, C and D.) One line runs across the horse just behind the withers. The other line runs from head to tail. The exhibitor is always one quadrant away from the judge. When the judge is in A, the handler should be in B. As the judge moves to C, the handler moves to A. As the judge goes into D, the handler moves to B. When the judge moves to B, the handler crosses to A. Thus, the exhibitor stands on the opposite side of the horse when the judge is toward the front and on the same side as the judge when the judge is toward the rear of the horse. At no time should the exhibitor change hands on the lead.

For safety reasons, the exhibitor does not stand directly in front of the horse (see Figure 5). As the judge views a horse directly from behind, the exhibitor stands on the side he/she was standing on immediately prior to the judge's movement to the rear of the horse.

Faults against the showman

Should not place above any showman who does not incur a severe fault – may receive a white ribbon

1. Failure to recognize and correct faults of the horse's position
2. Touching the horse with hands or feet
3. Switching hands on lead, two hands on lead or touching chain on lead
4. Failure of the horse to lead willingly
5. Failure to trot on request
6. Loud voice commands to the horse or excessive voice commands
7. Blocking the judge's view of the horse
8. Turning the horse the wrong direction. Turns greater than 90 degrees should be executed to the right.
9. Unruly horse that is not being controlled by the exhibitor

Figure 4. Quarters System

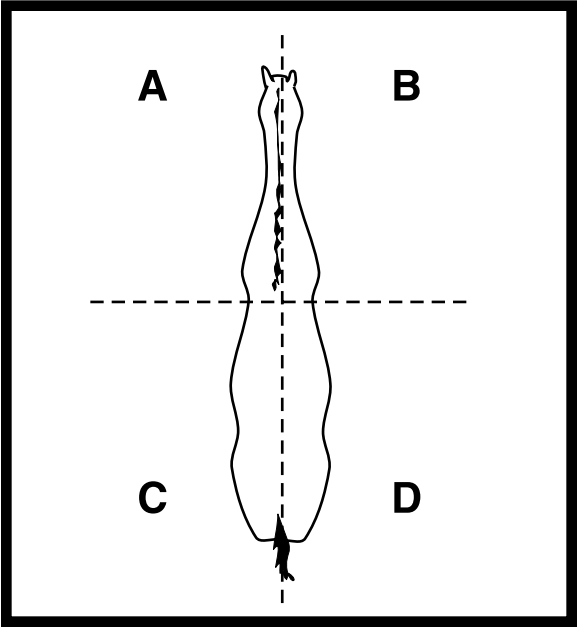
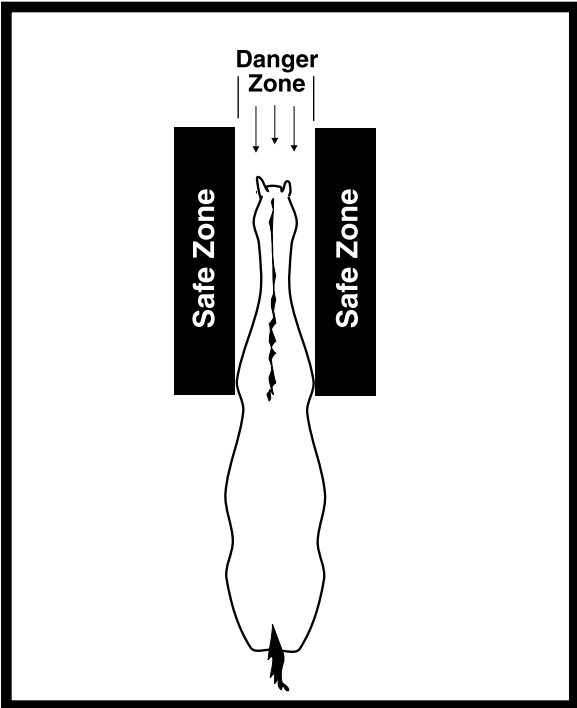

Figure 5. Safe Zone



10. Causing the judge to move to avoid being bumped or stepped on by the horse
11. Equipment improperly fitted
12. Leading on the off or right side

Disqualifications

Should receive the lowest ribbon placing — white ribbon

1. Failure to wear correct number
2. Willful abuse
3. Loss of control of the horse
4. Excessive schooling or training
5. Broken pattern — inclusion or exclusion of maneuvers, starting the pattern on the incorrect side of the cone

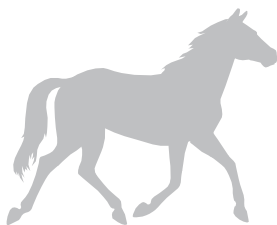

Western Class Routines

■ Western Horsemanship

Description

Western Horsemanship is designed to evaluate the rider's ability to effectively complete a specified pattern. This class is judged on pattern accuracy, rider body position and complete unison between rider and horse. The judge is looking for a rider who presents precision and smoothness in the pattern while exhibiting poise, confidence and a balanced, fundamentally correct body position throughout the class.

Class Routine

Each exhibitor will be asked to perform an individual pattern. Patterns will vary, but may include any maneuver normally required in a stock horse class; a list of possible tests is shown on page 25. Horses should work on a reasonably loose rein, without undue restraint.

Following the pattern, horses may be asked to work one or both ways of the arena at the walk, jog and lope. The judge may ask for additional work from any horse. The judge must ask for the back either in the pattern or on the rail.

Horses are to be reversed to the inside (away from the rail). Horses may be required to reverse at the walk or jog at the discretion of the judge. Horses will not be asked to reverse at the lope or to extend the lope.

Tack and Attire

1. Refer to the sections on Western Tack and Attire for Performance on pages 9 to 15.
2. Horse and saddle should be suited to the rider's ability and size.
3. Prohibited: mechanical hackamore, draw reins, tie-downs, martingale, cavesson nosebands, protective boots or leg wraps, crop, bat, whip, roping reins.

Scoring

A. Performance - 60 percent

1. Exhibitor should perform the work accurately, precisely, smoothly and with a reasonable amount of promptness.
2. Horse should perform all maneuvers in a willing manner.
3. Cadence should be kept throughout the performance.
4. Circles should be round and lines should be straight.
5. Transitions should be effortless and performed in the prescribed location.
6. Cues from the rider should be subtle.
7. Exhibitors are being judged from the time they enter the ring until dismissed by the judge or ring steward.

B. Body Position - 30 percent

1. Rider appears natural in the seat.
2. Rider sits deep in the saddle with knees slightly bent, weight distributed over the balls of his/her feet.
3. Legs hang to form a straight line from the ear, through the center of the shoulder and hip, touching the back of the heel or through the ankle (see Figure 6).
4. Shoulders are back, level and square.
5. Heels are lower than the toes, with a slight bend in the knee.
6. Knees point forward and remain closed with no space between the knee and the saddle.
7. Ball of the foot in the stirrup with toes running parallel or slightly turned out from the horse to help with grip.
8. Grip is a result of contact with the thigh, knee and calves of the leg.
9. Chin is level and eyes are forward.
10. Upper arm is in a straight line with the body.
11. The arm holding the reins is bent at the elbow, forming a line from the elbow to the horse's mouth.
12. Rein hand is carried immediately above or slightly in front of the saddle horn.
13. Free hand and arm should be carried either bent at the elbow in a similar position as the rein hand or straight down at the rider's side.
14. Rein hand is completely closed around the reins with only one finger between the reins (see Figure 6).
15. Hand on the reins should not be switched.
16. Excess reins fall on the same side as the rein hand.
17. If using a romal, rein hand is be wrapped completely around the reins, no fingers in between.

C. Suitability of Horse and Rider - 10 percent

1. Horse and rider are comfortable with each other.
2. Rider can control and maneuver the horse easily.
3. Exhibitor is not intimidated by the horse.

Optional List of Tests for Western Horsemanship

1. Ride without stirrups
2. Any combination of walk, jog and lope. Gaits may be performed in a straight line, circle, figure 8 or serpentine configuration.
3. Side passing
4. Backing maneuver
5. Pivots
6. Change of leads (simple or flying)
7. Performance on the rail

Note: These are just a few options from which the judge can choose.

**Figure 6. Correct Body Position for
Western Horsemanship**

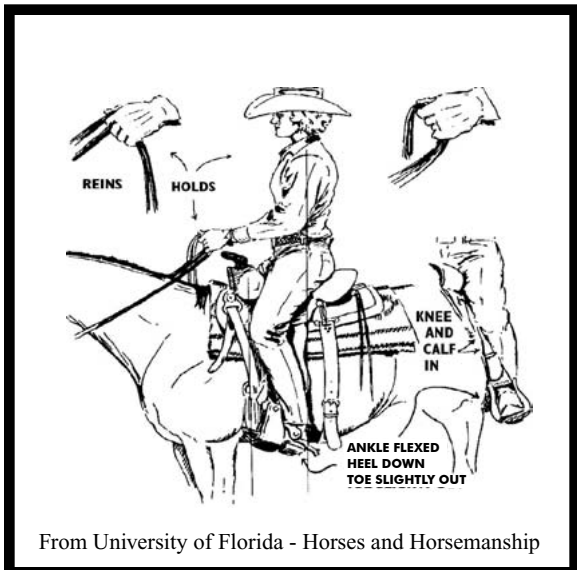

Severe Faults

Should not place above any rider who does not incur a fault — may receive a white ribbon

1. Touching the horse
2. Grabbing the saddle horn or any other part of the saddle
3. Incorrect lead or break of gait that is not corrected

Disqualifications

Should receive the lowest ribbon placing — white ribbon

1. Failure to wear correct number
2. Willful abuse
3. Spurring in front of the shoulder
4. Severe disobedience or resistance by horse, including, but not limited to, rearing, bucking or pawing
5. Loss of control of the horse
6. Excessive schooling or training
7. Broken pattern - inclusion or exclusion of maneuvers, starting the pattern or completing maneuvers on the incorrect side of the cone
8. Illegal use of hands on rein
 - a. Using two hands on reins with a curb bit
9. Illegal equipment

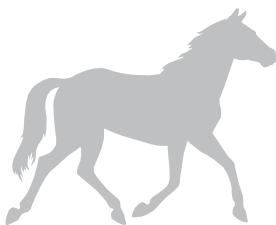

■ Reining

Description

Reining is a class that combines precision, style, speed, agility and brokenness. Each horse is judged on the neatness, dispatch, ease, calmness, and reasonable speed with which it performs one of the prescribed patterns. Horses should be guided easily with little or no apparent resistance throughout the entire pattern.

Class Routine

Each exhibitor will enter the arena individually and perform his/her pattern. In case of doubt, a judge may require any rider to repeat his/her performance of any or all the various parts of the pattern.

At the State Fair 4-H Horse Show, the judge at his/her discretion may utilize any of the AQHA official patterns (see AQHA rulebook for patterns) for the senior level.

Tack and Attire

1. Refer to Western Tack and Attire for Performance on pages 9 to 15.
2. **Optional:** protective boots, skid boots or leg wraps, *sliding plates* on hind feet
3. **Prohibited:** hackamores, gag bits, tie-downs, martingales, draw reins, cavesson noseband, any crop, whip or bat

Scoring

A. Scale

1. Each performance should be scored on a scale of 0 to infinity, with 70 denoting average.
2. Each maneuver should receive a maneuver score ranging from $+1\frac{1}{2}$ to $-1\frac{1}{2}$. The scale follows:
 - a. $-1\frac{1}{2}$ – extremely poor
 - b. -1 – very poor
 - c. $-\frac{1}{2}$ – poor
 - d. 0 – average
 - e. $+\frac{1}{2}$ – good
 - f. $+1$ – very good
 - g. $+1\frac{1}{2}$ – excellent

3. Each maneuver may or may not have penalties that are assessed.
4. Maneuver score and penalties are independent.
5. At the completion of the run, maneuver scores should be added or subtracted from a score of 70 and then penalty points should be subtracted.

B. Penalty Points

1. 5-point Penalties

- a. Spurring in front of cinch
- b. Use of either hand to instill fear or praise
- c. Holding saddle with either hand
- d. Blatant disobediences, including kicking, biting, bucking, rearing and striking

2. 2-point Penalties

- a. Break of gait
- b. Freeze up in spins or rollbacks
- c. On walk-in patterns, failure to stop or walk before executing a canter departure
- d. On run-in patterns, failure to be in a canter prior to the first marker
- e. If a horse does not completely pass the specified marker before initiating a stop position
- f. Jogging beyond two strides, but less than half a circle or half the length of the arena
- g. In patterns requiring a run-around, failure to be on the correct lead when rounding the end of the arena for more than half turn

3. 1-point Penalties

- a. Each time a horse is out of lead, a judge is required to deduct 1 point. The penalty for being out of lead is accumulative and the judge will deduct 1 penalty point for each quarter of the circumference of a circle or any part thereof that a horse is out of lead (Figure 7)
- b. Over- or underspinning from one-eighth to one-fourth of a turn (Figure 8)
- c. In patterns requiring a run-around, failure to be on the correct lead when rounding the end of the arena for half the turn or less

4. ½-point Penalties

- a. Starting a circle at a jog or exiting rollbacks at a jog up to two strides
- b. Over- or underspinning up to one-eighth of a turn
- c. Failure to remain a minimum of 20 feet from the wall or fence when approaching a stop and/or rollback
- d. Delayed change of lead by one stride

5. 0 Score – should receive the lowest ribbon possible – white ribbon

- a. Use of more than index or first finger between reins
- b. Use of two hands (exception in Junior, Snaffle Bit or Hackamore classes designated for two hands) or changing hands
- c. Use of romal other than as outlined

Figure 7. Penalties Associated With Lead Changes

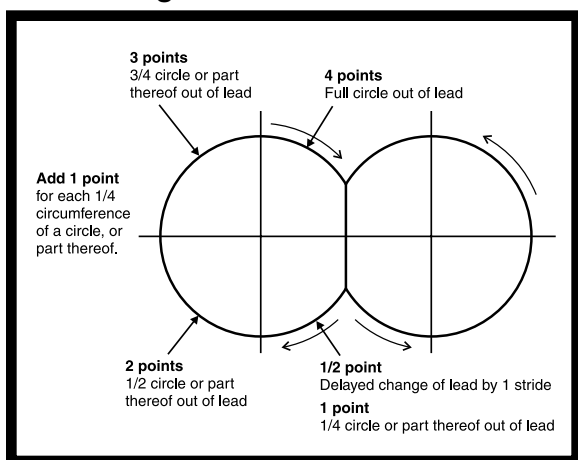
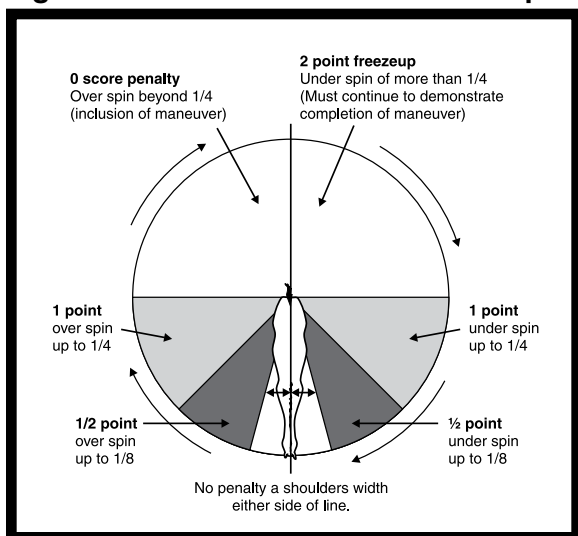

Figure 8. Penalties Associated With Spins



- d. Failure to complete pattern as written
 - e. Performing the maneuvers other than in specified order
 - f. Inclusion of maneuvers not specified, including, but not limited to:
 - i. Backing more than two strides
 - ii. Turning more than 90 degrees
 - g. Equipment failure that delays completion of pattern, including dropping a rein that contacts the ground while horse is in motion
 - h. Balking or refusal of command where pattern is delayed
 - i. Running away or failing to guide so that trying to discern whether the entry is on pattern becomes impossible
 - j. Jogging in excess of one-half circle or one-half the length of the arena
 - k. Overspins of more than one-quarter turn
 - l. Fall to the ground by horse or rider
- 6. No Score – Should receive the lowest ribbon possible – white ribbon**
- a. Abuse of an animal in the show arena and/or evidence that an act of abuse has occurred prior to or during the exhibition of a horse in competition
 - b. Use of illegal equipment, including wire on bits, bosals or curb chains
 - c. Use of illegal bits, bosals or curb chains; when using a snaffle bit, optional curb strap is acceptable; however, curb chains are not acceptable
 - d. Use of tack collars, tie-downs or nose bands
 - e. Use of whips or bats
 - f. Use of any attachment that alters the movement of or circulation to the tail
 - g. Failure to provide horse and equipment to the appropriate judge for inspection
 - h. Disrespect or misconduct by the exhibitor
 - i. Closed reins are not allowed except as standard romal reins
- 7. Neither a no score or a 0 score is eligible to place in a go round or class, but a 0 may advance in a multigo event, while a no score may not.**

C. Considerations

1. Credits

- a. Smooth, level, simultaneous lead changes
- b. Flat, quick spins with a stationary pivot foot
- c. Straight stops with haunches dropped in the ground
- d. Round circles showing size and speed changes
- e. Quick straight backing over the slide tracks
- f. Prompt rollbacks and departures

2. Faults

- a. Opening mouth excessively when wearing bit
- b. Excessive jawing, opening mouth or head raising on stop
- c. Lack of smooth, straight stop on haunches; bouncing or sideways stop
- d. Refusing to change leads
- e. Anticipating signals
- f. Stumbling
- g. Backing sideways
- h. Knocking over markers

3. Lead changes should occur at the center point of the figure 8.

- a. Each pattern lists the type of lead change desired
- b. Smoothness of performance
- c. Steadiness of gaits and response to the rider
- d. Abusive use of the mouth of the horse is scored accordingly

Reining Pattern No. 1 Junior Reining

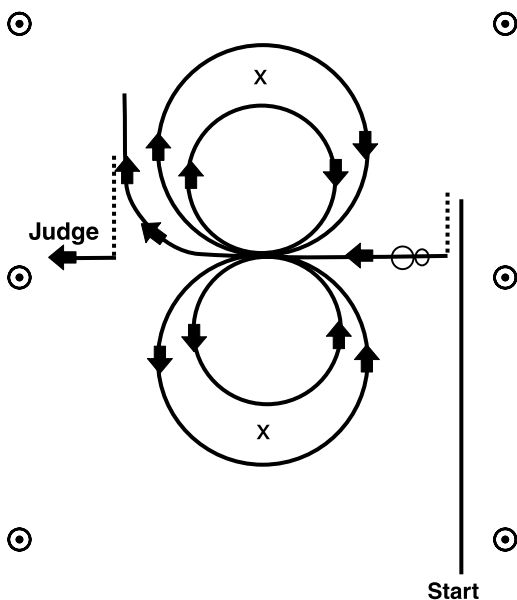

1. Lope in a straight line at least 20 feet away from the wall. Stop and back to center of arena. Hesitate.
2. Complete one spin to the right.
3. Do $1\frac{1}{4}$ spin to the left.
4. Ride a small, slow circle to the right inside the marker. Ride a large, fast circle to the right outside the marker. Execute a simple lead change.
5. Ride a small, slow circle to the left inside the marker. Ride a large, fast circle to the left outside the marker. Execute a simple lead change.
6. Lope off on the right lead, stop before reaching the end marker. Settle horse.
7. Ride to judge for inspection.
8. The bridle may be dropped at the judge's discretion.

Reining Pattern No. 2 Junior Reining

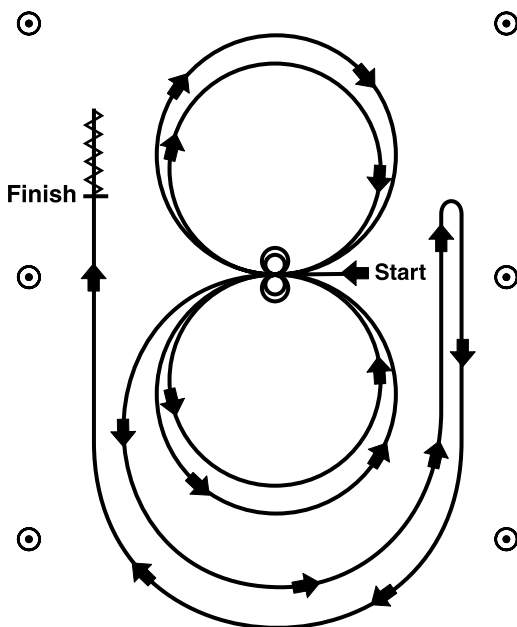

1. Start in the center of the arena facing the left wall.
2. Complete two spins to the right.
3. Complete two spins to the left.
4. Beginning on the left lead, complete two circles to the left, the first small and slow; the second circle large and fast. Flying lead change of leads at the center.
5. Complete two circles to the right, the first small and slow; the second circle large and fast. Flying lead change of leads at the center.
6. Begin a large, fast circle to the left but do not close this circle. Run straight down the right side of the arena past the center marker and do a right rollback at least 20 feet from the wall or fence.
7. Continue back around the previous circle, run down the left wall at least 20 feet from the wall past the center marker and do a sliding stop. Back up to center of arena. Hesitate.
8. Ride to judge for inspection.
9. The bridle may be dropped at the judge's discretion.

Reining Pattern No. 3 Junior Reining

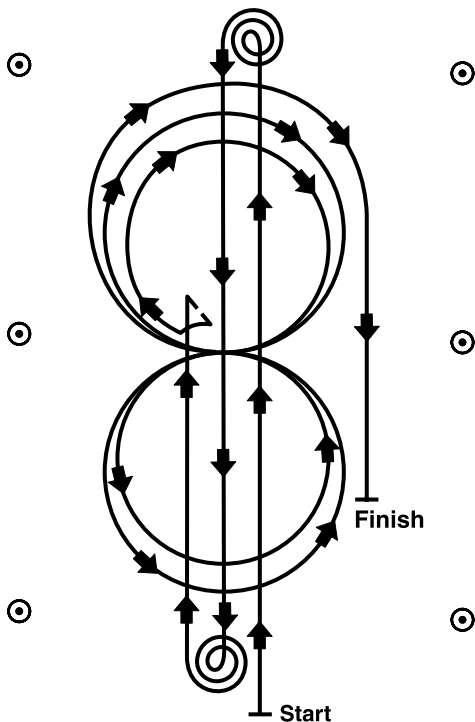

1. Run to far end of arena past end marker, stop and complete 2½ spins to the left.
2. Run to opposite end of arena past end marker, stop and complete 2½ spins to the right.
3. Run past center marker and do a sliding stop. Back up to the center of the arena. Hesitate.
4. Make ¼ pivot to the left. Begin on the right lead and make two circles to the right, the first small and slow, the second large and fast. Flying change of leads at center of arena.
5. Make two circles to the left, first small and slow, the second large and fast. Flying change of leads at center of arena.
6. Begin a large, fast circle to the right. Do not close this circle, but run straight down the side past the center and do a sliding stop at least 20 feet from the wall.
7. Hesitate to show completion. Ride to judge for inspection.
8. The bridle may be dropped at the judge's discretion.

Reining Pattern No. 4 Senior Division

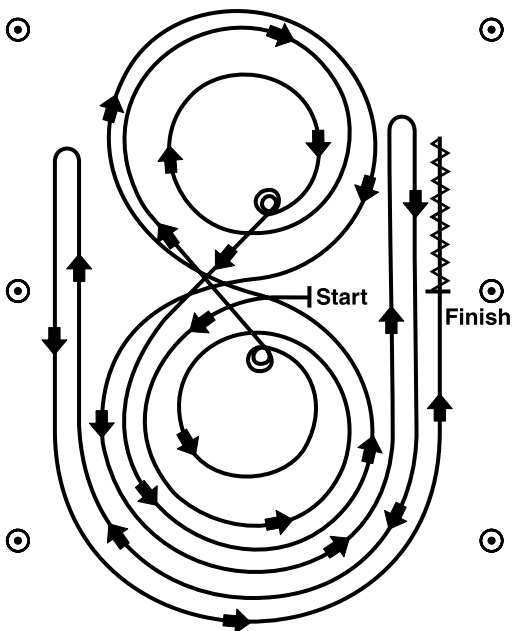

1. Begin at the center of the arena facing the left wall.
2. Beginning on the left lead, complete two circles to the left, the first large and fast, the second small and slow. Stop at the center of the arena.
3. Complete two spins to the left, hesitate.
4. Beginning on the right lead, complete two circles to the right, the first circle large and fast, the second circle small and slow. Stop at the center of the arena.
5. Complete two spins to the right.
6. Begin on left lead and make a figure 8 on top of the large circles, flying change of leads at center of arena.
7. Close figure 8 and begin large, fast circle to the left. Do not close this circle, but run straight down the side past center marker and do a right rollback at least 20 feet from the wall.
8. Continue back around previous circle. Do not close this circle, but run straight down the side past the center marker and do a sliding stop at least 20 feet from the wall, left rollback.
9. Continue back around previous circle. Do not close this circle, but run straight down the side past the center marker and do a sliding stop at least 20 feet from the wall.
10. Back over slide tracks. Hesitate to show completion.
11. Ride to judge for inspection.
12. The bridle may be dropped at the judge's discretion.

Reining Pattern No. 5 Senior Division

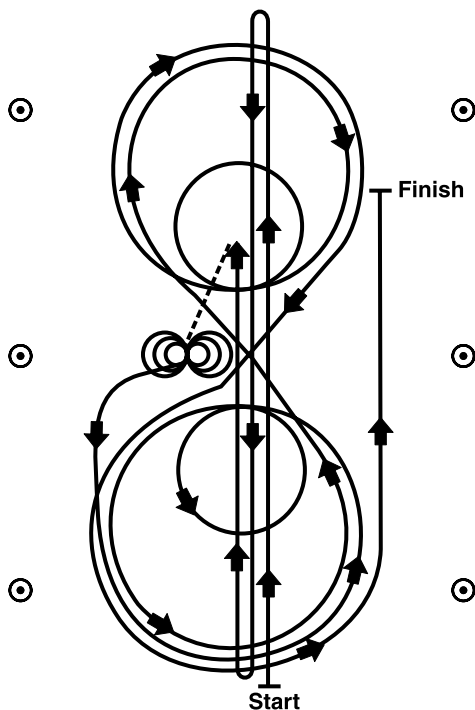

1. Run with speed to the far end of the arena past the end marker and do a left rollback.
2. Run to the opposite end of the arena past the end marker and do a right rollback.
3. Run past the center marker and do a sliding stop. Back up to the center of the arena.
4. Complete three spins to the right.
5. Complete 3¼ spins to the left.
6. Start on the left lead. Complete three circles to the left, the first large, fast; the second small, slow; the third circle large, fast. Flying change of leads at the center of the arena.
7. Complete three circles to the right, the first large, fast; the second small, slow; the third circle large, fast. Flying change of leads at the center of the arena.
8. Begin a large fast circle to the left, but do not close this circle. Run straight down the right side of the arena at least 20 feet off the wall past the center marker and do a sliding stop. Hesitate.
9. Ride to judge for inspection.
10. The bridle may be dropped at the judge's discretion.

Reining Pattern No. 6 Senior Division

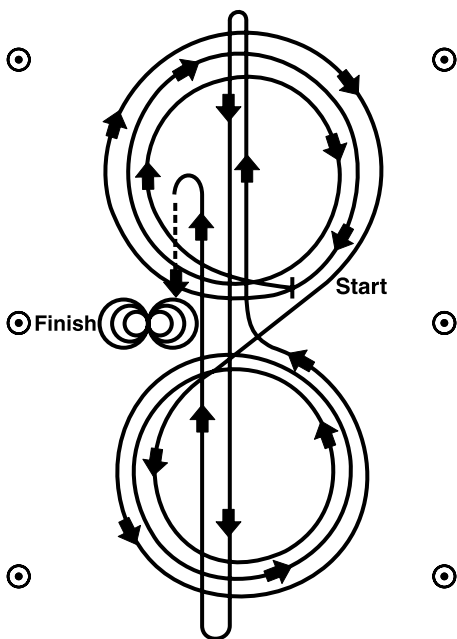

1. Beginning on the right lead, complete three circles to the right, the first one small and slow; the second and third large and fast. Flying change of leads at the center of the arena.
2. Complete three circles to the left, the first one small and slow; the second and third large and fast. Flying change of leads at the center of the arena.
3. Turn up the middle of the arena and run to the far end past the end marker, do a sliding stop and rollback to the left.
4. Run to opposite end of arena past end marker, do a sliding stop and a right rollback.
5. Run past center, stop and back to center.
6. Complete three spins to the left.
7. Complete three spins to the right. Hesitate.
8. Ride to judge for inspection.
9. The bridle may be dropped at the judge's discretion.

■ Trail

Description

Trail is judged on the performance of the horse over obstacles. Emphasis is placed on manners, response to rider's cues and ability to maneuver through the course with style and precision. The judge will credit a horse that is attentive and able to pick its own way through the obstacles with minimal rider input.

Class Routine

This is strictly an individual pattern class; no rail work is required. The pattern will consist of six to 10 obstacles. Throughout the course of the pattern, horses must demonstrate all three gaits: walk, jog/trot and lope/canter. Trial has three mandatory obstacles: gate, four logs and a back-through. The other obstacles are chosen by each individual show committee. Keep in mind, obstacles should be designed to be challenging to the competitors, but should not endanger or set the horse up for failure. The judge may alter the course or remove any obstacle he/she feels may be dangerous.

Each participant will be allowed three chances at each obstacle. If the obstacle cannot be completed in those three attempts, the contestant will be asked to move on to the next obstacle and will receive a 0 score *for the obstacle*. Contestants may choose to pass an obstacle if they feel unsafe after one attempt. This will result in a 0 score on that obstacle, not a 0 score overall.

Trail may be judged by one judge or by a group of judges, depending on class size and show committee preference. In either case, participants should wait until the judge at each obstacle acknowledges he/she is ready to begin the obstacle. Failure to wait for the judge to be ready before beginning the obstacle may result in a 0 score for that obstacle.

Tack and Attire

1. Refer to Western and English Tack and Attire for Performance on pages 9 to 16.
2. **Prohibited:** hackamores, protective leg boots, gag bits, tie-downs, martingales, draw reins, cavesson noseband, any crop, whip or bat

Scoring

A. Scale

1. Each obstacle will be scored on a 0-10 scale, with 0 being a no score for the obstacle and 10 being the maximum score for the obstacle.
2. Penalties will be subtracted from the maximum 10 score per obstacle.
3. The obstacle score will take into consideration both the penalties and the maneuver score for each obstacle.
4. Contestants cannot receive a negative score on an obstacle even if they incur more than 10 penalty points. The lowest score possible per obstacle is a 0.
5. At the end of each run, the total will be added up for all obstacles and ranked according to overall points available. For example, if the trail course has eight obstacles, the maximum score for the course is an 80.

B. Penalty Points

1. ½-point Penalties

- a. Each tick of log, pole, cone or obstacle

2. 1-point Penalties

- a. Each hit of or stepping on a log, pole, cone or obstacle
- b. Break of gait at walk or jog for two strides or less
- c. Both front or hind feet in a single-strided slot or space
- d. Skipping over or failing to step into required space
- e. Split pole in lope-over
- f. Failure to meet the correct strides on trot-over and lope-over log obstacles

3. 3-point Penalties

- a. Break of gait at walk or jog for more than two strides
- b. Out of lead or break of gait at lope (except when correcting an incorrect lead)
- c. Knocking down an elevated pole, cone, barrel or plant obstacle, or severely disturbing an obstacle
- d. Stepping outside the confines of, falling or jumping off or out of an obstacle with **one foot**
- e. First refusal, balk or attempting to evade an obstacle by shying or backing more than **two strides** away
- f. Second refusal, balk or attempting to evade an obstacle by shying or backing more than two strides away

4. 5-point Penalties

- Dropping slicker or object
- Letting go of gate or dropping rope gate
- Use of either hand to instill fear or praise
- Stepping outside the confines of, falling or jumping off or out of an obstacle with **more than one foot**
- Blatant disobedience (kicking out, bucking, rearing, striking)

5. 0 Obstacle Score

- Third refusal or evade
- Ride outside course boundary
- Wrong lead through entire obstacle
- Failure to complete an obstacle
- Wrong line of travel
- Use of two hands when riding with a Western curb bit
- Incurring more than 10 penalty points

6. 0 Overall Score – Should receive the lowest placing possible – white ribbon

- Completing obstacles out of order
- Fall to ground by horse or rider
- Failure to complete course

Figure 9. Example Trot and Lope-over Obstacles

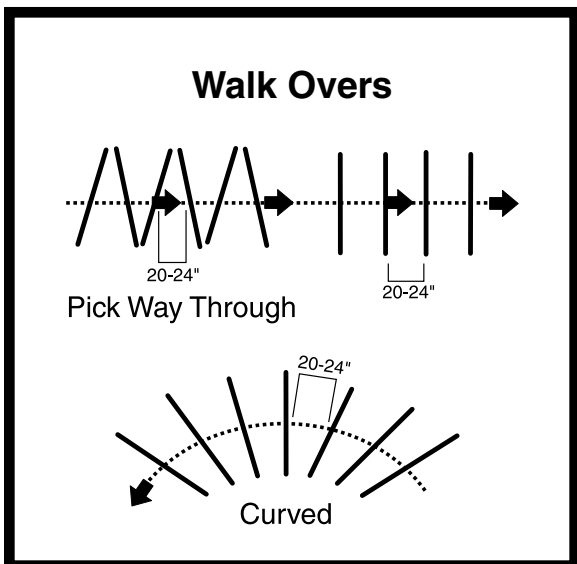
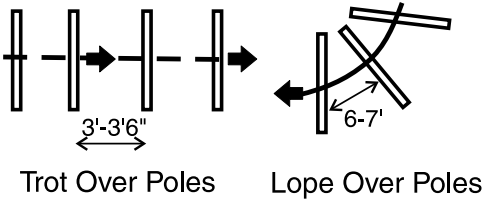

Figure 9. Example Trot and Lope-over Obstacles (continued)

Trot Overs, Lope Overs



Trot Overs, Lope Overs and Walk Overs

Can Use Walk Overs, Trot Overs & Lope Overs in One Class

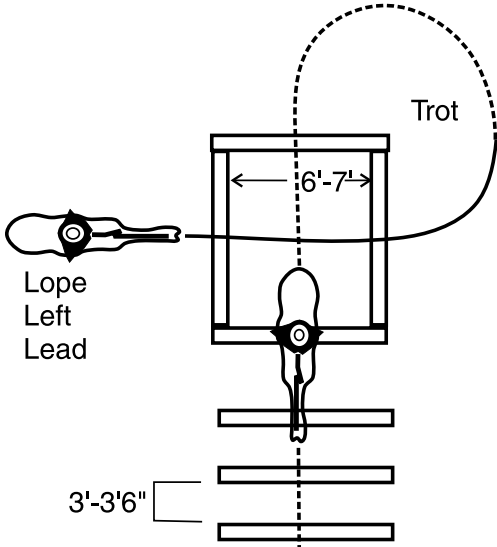

Widths may be Doubled or Tripled to allow for more than one stride between poles.

Figure 10. Examples of Side-passing Obstacles

Variations of Sidepass

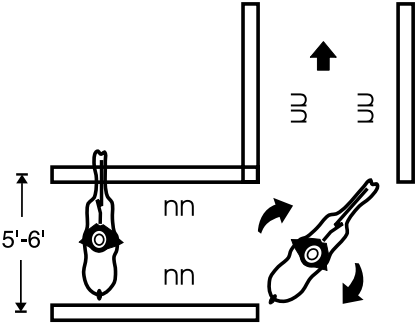

Sidepass Right, Turn Right
Sidepass Left

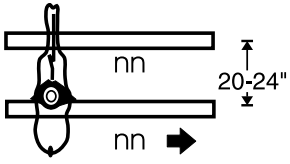

Front Feet Inside or
Back Feet Inside

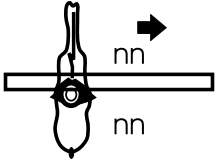

Raised Object
(No more than 12")

Figure 11. Variations of Sidepass

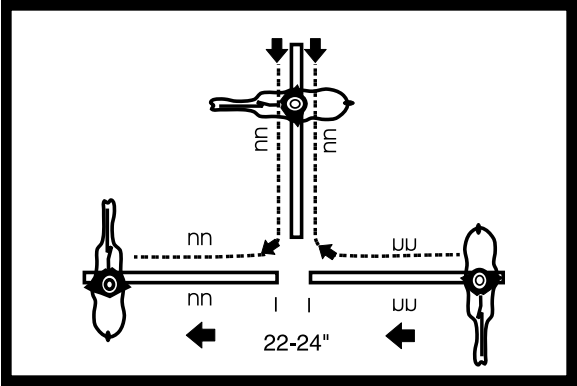
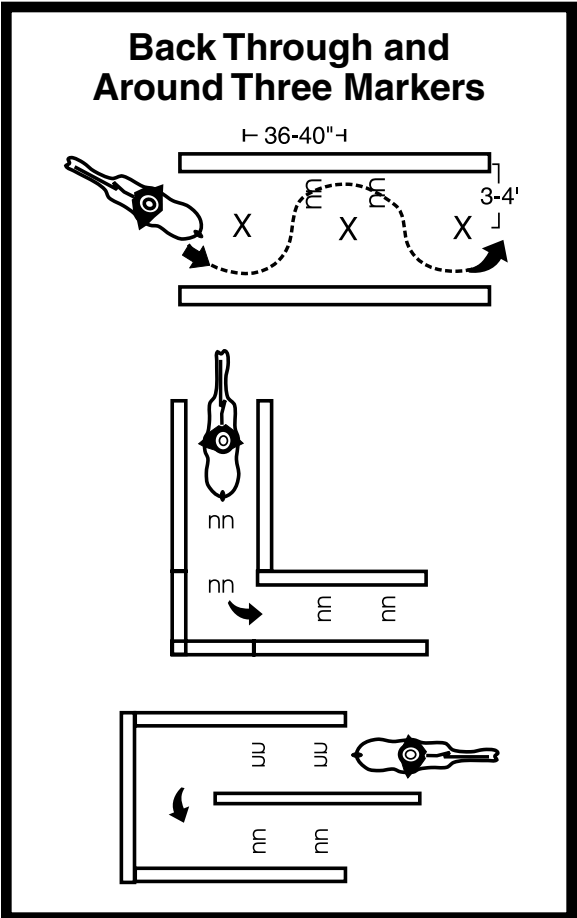

Figure 12. Variations of Backing Obstacles



■ Western Riding

Description

Western riding is a combination class designed to show characteristics of a good, sensible, well-mannered, free and easy moving horse. This advanced class utilizes skills found in Horsemanship, Reining and Trail classes. Riders should not compete in Western Riding until they are proficient in these other classes. **If riders are unable to complete controlled, flying lead changes, they should not enter Western Riding.**

Class Routine

Each rider individually enters the ring to perform one of the prescribed patterns. Each horse should rein and handle easily, fluently and effortlessly throughout the pattern. This is a judged class, not a timed class, and excessive speed will be penalized.

Tack and Attire

1. Refer to Western Tack and Attire for Performance on pages 9 to 15.
2. Horse and saddle should be suited to the rider's ability and size.
3. **Optional:** protective leg boots
4. **Prohibited:** mechanical hackamore, gag bits, draw reins, tie-downs, martingales, crop, bat, whip, roping reins.

Scoring

A. Scale

1. Each performance should be scored on a scale of 0-100, with 70 denoting average.
2. Each maneuver should receive a maneuver score ranging from +1½ to -1½. The scale follows:
 - a. -1½ – extremely poor
 - b. -1 – very poor
 - c. -½ – poor
 - d. 0 – average
 - e. +½ – good
 - f. +1 – very good
 - g. +1½ – excellent

3. Each maneuver may or may not have penalties that are assessed.
4. Maneuver score and penalties are independent.
5. At the completion of the run, maneuver scores should be added or subtracted from a score of 70 and then penalty points should be subtracted.

B. Penalty Points

1. 5-point Penalties

- a. Out of lead beyond the next designated change area (note: failure to change, including *cross-cantering*. Two consecutive failures to change would result in two 5-point penalties)
- b. Blatant disobedience, including kicking out, biting, bucking and rearing

2. 3-point Penalties

- a. Not performing the specific gait (jog or lope) or not stopping when called for in the pattern within 10 feet of the designated area
- b. Simple change of leads
- c. Out of lead at or before the marker prior to the designated change area or out of lead at or after the marker after the designated change area
- d. Additional lead changes anywhere in pattern (except when correcting an extra change or incorrect lead)
- e. Failure to start the lope within 30 feet after crossing the log at the jog
- f. Break of gait at walk or jog for more than two strides
- g. Break of gait at the lope

3. 1-point Penalties

- a. Hitting or rolling log
- b. Out of lead more than one stride either side of the center point and between the markers
- c. Splitting the log (log between the two front or two hind feet) at the lope
- d. Break of gait at the walk or jog up to two strides

4. ½-point Penalties

- a. Tick or light touch of log
- b. Hind legs skipping or coming together during lead change
- c. Nonsimultaneous lead change (front to hind or hind to front)

- 5. 0 Score – should receive lowest ribbon possible – white ribbon**
- a. Illegal equipment
 - b. Willful abuse
 - c. Off course
 - d. Knocking over markers
 - e. Completely missing log
 - f. Major refusal – stop and back more than two strides or four steps with front legs
 - g. Major disobedience or schooling
 - h. Failure to start lope prior to end cone
 - i. Four or more simple lead changes and/or failures to change leads
 - j. Overturn of more than one-quarter turn
 - k. Use of two hands on reins when using a curb bit
- 6. Credits**
- a. Simultaneous changes
 - b. Accurate and smooth pattern
 - c. Even pace throughout the pattern
 - d. Easily guided and controlled
 - e. Manners and disposition
- 7. Faults**
- a. Opening mouth excessively
 - b. Anticipating signals
 - c. Stumbling
 - d. Improper head set or carriage
 - e. Excessive speed

C. Considerations

1. Change of leads
 - a. Flying changes of leads to be used throughout the class.
 - b. Preference is given to flying changes that occur midway between the markers throughout the entire class. (Figure 13)
 - c. Lead changes are done in a controlled manner.
2. Smoothness of performance
3. Steadiness of gaits and response to the rider
4. Abusive use of the mouth of the horse is scored accordingly

Figure 13. Location of Lead Changes and Penalties

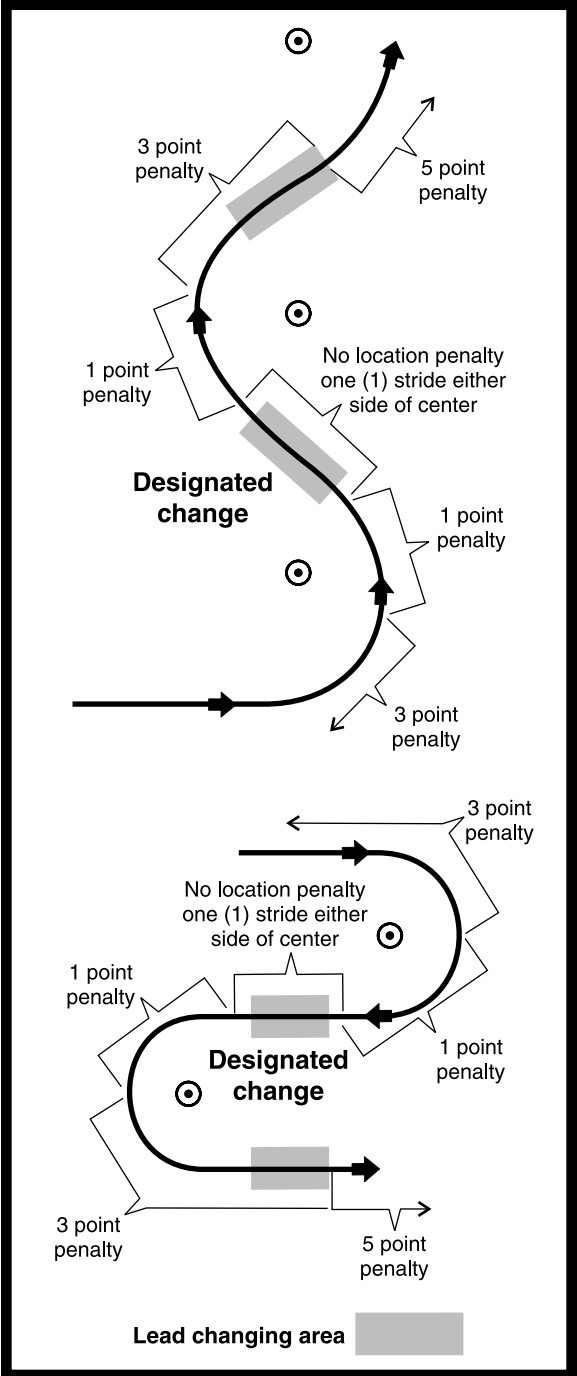

D. Patterns

1. In the pattern diagrams, the markers represent pylons.
2. The markers are separated by a uniform distance of not less than 30 or more than 50 feet. The distance may be altered according to local conditions.
3. The lines and arrows represent line of travel. Dotted line-walk, dashed line-jog and solid line lope.

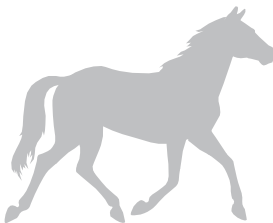

Western Riding Pattern 1

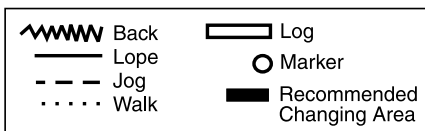
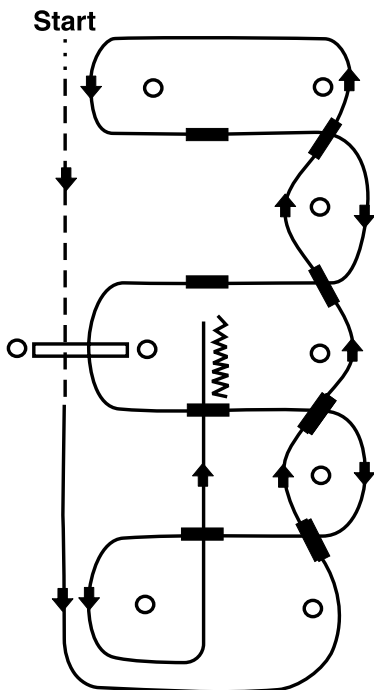

1. Walk & jog over log
2. Transition to left lead & lope around end
3. First line change
4. Second line change
5. Third line change
6. Fourth line change & lope around the end of arena
7. First crossing change
8. Second crossing change
9. Lope over log
10. Third crossing change
11. Fourth crossing change
12. Lope up the center, stop & back

Western Riding Pattern 2

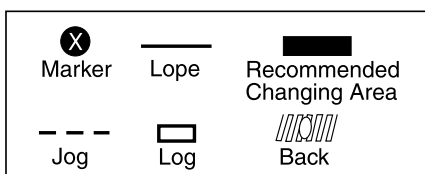
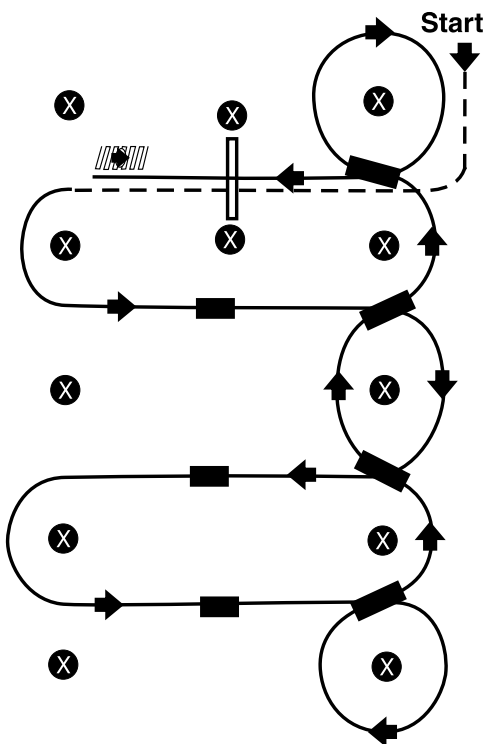

1. Walk, transition to jog, jog over log
2. Transition to lope
3. First crossing change
4. Second crossing change
5. Third crossing change
6. Circle & first line change
7. Second line change
8. Third line change
9. Fourth line change & circle
10. Lope log
11. Lope, stop & back

■ Western Pleasure

Description

Western pleasure is designed to demonstrate a horse's brokenness, consistency and quality of movement. A good pleasure horse should have a natural flat-footed, four-beat walk. It should exhibit a smooth, soft and distinct two-beat jog. The lope should be a consistent, slow and rhythmical three-beat gait. Horses should carry their head in a relaxed and natural position. Western pleasure horses should travel on a relatively loose rein with little guidance from the rider and should look very similar when traveling both directions of the arena. Horses should be judged according to their breed rules and standards.

Class Routine

Horses are to enter the arena single file either at a walk or jog as directed by the judge. Horses shall demonstrate a walk, jog and lope in both directions of the arena. Horses always should be reversed away from the rail and never should be asked to reverse at a lope. When working on the rail, slower-moving horses should remain closest to the rail and any passing should be done on the inside (toward the middle of the arena) of the slower-moving horse. Adequate space should be created between the passing horses before returning to the rail. A rider never should pass between another horse and the rail. At the judge's discretion, horses may be backed individually in the center of the arena or as a group on the rail. The judge may ask for additional work from any or all contestants, including but not limited to: extended trot or lope, reverse at walk or jog, stop from any gait and transition between gaits. An extended gait should be a lengthening of the stride and more reach from the shoulder with very little change in the speed of the animal. Excessive speed will be penalized. Riders will not be asked to dismount unless the judge requests an equipment check.

Tack and Attire

1. Refer to the sections on Western Tack and Attire for Performance on Pages 9 to 15.
2. Horse and saddle should be suited to the rider's ability and size.
3. Prohibited: mechanical hackamores, draw reins, tie-downs, martingales, cavesson nosebands, protective boots or leg wraps, crops, bats, whips, roping reins.

Scoring

Each gait in this class should be ranked on a scale of good, average or below average. A horse receiving mostly above-average marks should receive a blue ribbon. Horses scoring average in most fields should receive a red ribbon and horses scoring below average for the majority of the class should receive a white ribbon. A description of gaits and appropriate score follows.

Western Pleasure

Gait	Good	Average	Below Average
Walk	Ground-covering, flat-footed, four-beat gait, straight and true	Slow, nonrhythmical gait	Stopping and starting, nervous jogging
Jog	Smooth, two-beat diagonal gait, consistent speed, steady, cadenced	Faster moving, more unsteady with head carriage, slight handling by rider	Not keeping a two-beat jog, changing speed
Lope	Cadenced three-beat gait, consistent, slow-legged movement	Cadenced, consistent, requires more guidance from the rider	Unbalanced head carriage, lacking three-beat lope, fast, requires lots of guidance
Extended Jog	Good lengthening of stride, stays steady with head	Slight increase in speed, requires more guidance	Inconsistent speed, failure to increase stride length, breaks gait, pushy
Back	Responsive, backs straight and willingly	Slight hesitation, backs crookedly	Throws head, pulls on bit, fails to back

Western Pleasure (continued)

Gait	Good	Average	Below Average
Attitude	Ears forward, tail quiet, travels on a loose rein, attentive to rider's cues, looks straight through the bridle when traveling, remains quiet at the bit, maintains constant speed and cadence, demonstrates smooth transitions with little handling	Horse not attentive, requires slight handling from the rider, may exhibit a combination of good and below-average qualities	Pinned ears, wringing of tail, constant chomping of the bit, horse requires constant handling by the rider, gets pushy during transitions

Severe Faults

Should not place above any rider who does not incur a fault — may receive a white ribbon

1. Incorrect lead or break of gait that is not corrected
2. Touching the horse
3. Grabbing the saddle horn or any other part of the saddle
4. Exhibiting a four-beat gait at the lope or jog
5. Excessive speed
6. Horse requires excessive handling by the rider to maintain control

Disqualifications

Should receive the lowest ribbon placing — white ribbon

1. Failure to wear correct number
2. Willful abuse
3. Spurring in front of the shoulder
4. Severe disobedience or resistance by horse, including but not limited to rearing, bucking or pawing

5. Loss of control of the horse
6. Excessive schooling or training
7. Illegal use of hands on rein (for example, using two hands with a curb bit)
8. Illegal equipment

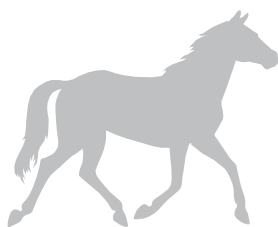

■ Ranch Horse Pleasure

Description

The purpose of the Ranch Horse Pleasure class is to reflect the versatility, attitude and movement of a working horse. The horse's performance should be indicative of a working horse riding outside on the ranch/trail. The horse should work at a forward, working speed while remaining under control at all times. Note: This is not a timed event, and excessive speed will be penalized. Horses exhibited with light contact on the reins should be rewarded; loose or full drape of rein is not necessary. Overall manners, responsiveness of the horse while performing and the horse's quality of movement are the primary considerations.

Class Routine

This is strictly an individual pattern class; no rail work is required. Each horse will work individually, performing the maneuvers as depicted in the three available patterns. The overall cadence and performance of the gaits should be as described in the section on Western Pleasure (pages 52-53), with an emphasis on forward movement, and free-flowing and ground-covering gaits. Transitions should be performed where designated, with smoothness and responsiveness.

No time limit has been set for performing the pattern, and excessive/uncontrolled speed should be penalized.

Tack and Attire

1. Refer to Western and Tack and Attire for Performance on Pages 9 to 16.
2. Prohibited: mechanical hackamores, draw reins, tie-downs, martingales, cavesson nosebands, protective boots or leg wraps, crops, bats, whips, roping reins.

Scoring

A. Scale

Each performance should be scored on a scale of 0-100, with 70 denoting average.

Severe Faults

Should not place above any rider who does not incur a fault — may receive a white ribbon

1. Failure to complete an attempted maneuver required in the pattern
2. Incorrect lead or break of gait that is not corrected
3. Touching the horse
4. Grabbing the saddle horn or any other part of the saddle
5. Exhibiting a four-beat gait at the lope or jog
6. Excessive speed or excessive slowness
7. Horse requires excessive handling by the rider to maintain control

Disqualifications

Should receive the lowest ribbon placing — white ribbon

1. Failure to complete the pattern
2. Failure to wear correct number
3. Willful abuse
4. Spurring in front of the cinch
5. Severe disobedience or resistance by horse, including but not limited to rearing, bucking or pawing
6. Loss of control of the horse
7. Excessive schooling or training
8. Illegal use of hands on rein (for example, using two hands with a curb bit)
9. Illegal equipment

Ranch Pleasure Pattern 1

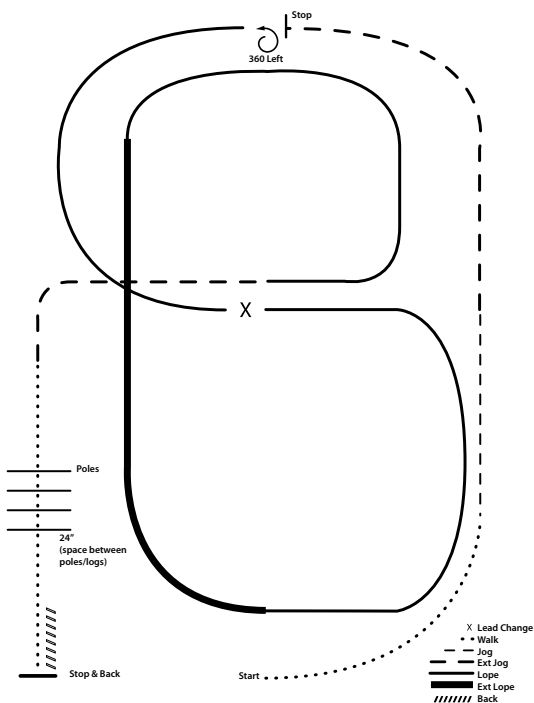

1. Walk
2. Jog
3. Extend the jog ,at the top of the arena ,stop
4. 360 turn to the left
5. Left lead $\frac{1}{2}$ circle, lope to the center
6. Change leads (simple or flying)
7. Right lead $\frac{1}{2}$ circle
8. Extended lope up the long side of the arena (right lead)
9. Collect back to a lope around the top of the arena and back to center
10. Break down to a jog
11. Walk over poles
12. Stop and back

Ranch Pleasure Pattern 2

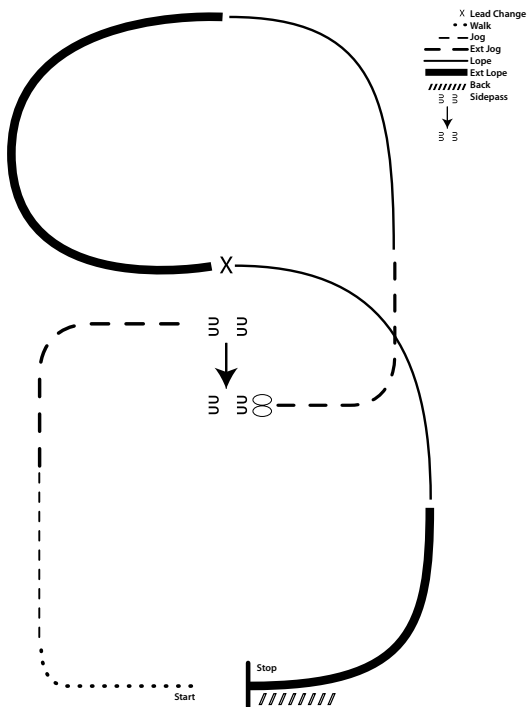

1. Walk to the left around corner of the arena
2. Jog
3. Extend alongside of the arena and around the corner to center
4. Stop, side pass right
5. 360 turn each direction (either way 1st)
6. Extend the jog
7. Lope left lead
8. Extend the lope
9. Change leads (simple or flying)
10. Collect to the lope
11. Extend the lope
12. Stop and back

Ranch Pleasure Pattern 3

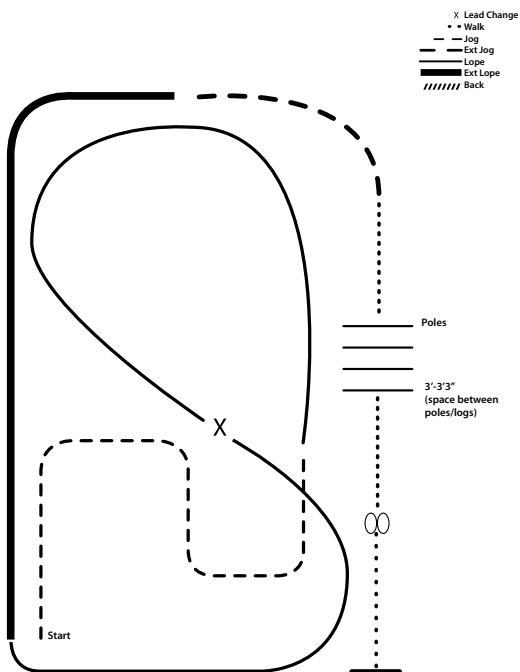

1. Jog serpentine
2. Lope left lead around the end of the arena and then diagonally across the arena
3. Change leads (simple or flying) and lope on the right lead around end of the arena
4. Extend lope on the straight away and around corner to the center of the arena
5. Extend jog around corner of the arena
6. Collect to a jog, jog over poles
7. Stop, do 360 turn each direction (either direction 1st) (L-R or R-L)
8. Walk

English Class Routines

■ Hunt Seat Equitation

Description

Hunt Seat Equitation is designed to evaluate the rider's ability to perform various maneuvers in harmony with his/her horse. This class measures communication between horse and rider, rider position and performance. The judge is looking for a stylish ride, one with smoothness and precision in the pattern while maintaining correct body position.

Class Routine

Each exhibitor will be asked to perform an individual pattern. Patterns will vary, but may include any maneuver normally required in a Hunt Seat class; a list of possible tests is shown on page 55. Light contact should be kept with the horse's mouth at all times.

Following the pattern, horses may be asked to work one or both ways of the arena at the walk, trot and canter. The judge may ask for additional work from any horse. The judge must ask for the back either in the pattern or on the rail. Riders will not be asked to jump during Hunt Seat Equitation.

Horses are to be reversed to the inside (away from the rail). Horses may be required to reverse at the walk or trot at the discretion of the judge. Horses will not be asked to reverse at the canter.

Tack and Attire

1. Refer to English Tack and Attire for Performance on pages 9 to 16.
2. Horse and saddle should be suited to the rider's ability and size.
3. **Prohibited:** mechanical hackamore, draw reins, tie-downs, martingales, protective boots, leg wraps, roping reins.

Scoring

A. Performance - 60 percent

1. Exhibitor should perform the work accurately, precisely, smoothly and with a reasonable amount of promptness.
2. Horse should perform all maneuvers in a willing manner.
3. Cadence should be kept throughout the performance.
4. Circles should be round and lines should be straight.
5. Transitions should be effortless and performed in the prescribed location.
6. Cues from the rider should be subtle.
7. Exhibitors are being judged from the time they enter the ring until dismissed by the judge or ring steward

B. Body Position - 30 percent

1. Rider should have a workmanlike appearance, seat and hands light and supple, conveying the impression of complete control if any emergency should arise.
2. Place hands over and in front of the horse's withers, knuckles 30 degrees inside the vertical, hands slightly apart and making a straight line from horse's mouth to rider's elbow. Method of holding reins is optional and **bight of reins** may fall on either side. However, pick up all reins at the same time.
3. The eyes are up and shoulders back.
4. Place toes at an angle best suited to the rider's conformation.
5. Ankles flexed in, heels down, calf of leg in contact with horse and slightly behind the **girth** (Figure 14). For the most balanced position, the rider's leg should have a slight bend and should be in a position that the heel is in line with the hip. This position is usually where the leather hangs straight down from the point of attachment.
6. The iron is on ball of the foot or home (against the heel) and must not be tied to the girth.
7. At the walk, the rider should be in a vertical position (Figure 15).
8. **Posting** trot – at left **diagonal**, rider should be sitting the saddle when the left front leg is on the ground; at right diagonal, rider should be sitting the saddle when right front leg is on the ground; when circling clockwise at the trot, rider should be on the left diagonal; when circling counter-clockwise, rider should be on the right

diagonal. Rider should close the hip angle to allow the torso to follow the horizontal motion of the horse, resulting in the upper body being 20 degrees in front of the vertical (Figure 15).

9. Sitting trot and canter, the upper body is slightly in front of the vertical (Figure 15).
10. In two-point, the pelvis is shifted forward and the rider's weight should come off the horse's back and be transferred into the rider's legs. Hands should be forward, but not resting on the horse's neck. The rider's upper body should be 30 degrees in front of vertical.
11. Hand gallop — a three-beat lengthened canter ridden in two-point position.
12. Leg position should not change from gait to gait.

C. Suitability of Horse and Rider - 10 percent

1. Horse and rider should be comfortable with each other.
2. Rider can easily control and maneuver the horse.
3. Exhibitor should not be intimidated by the horse.

Figure 14. Examples of Proper Leg Position

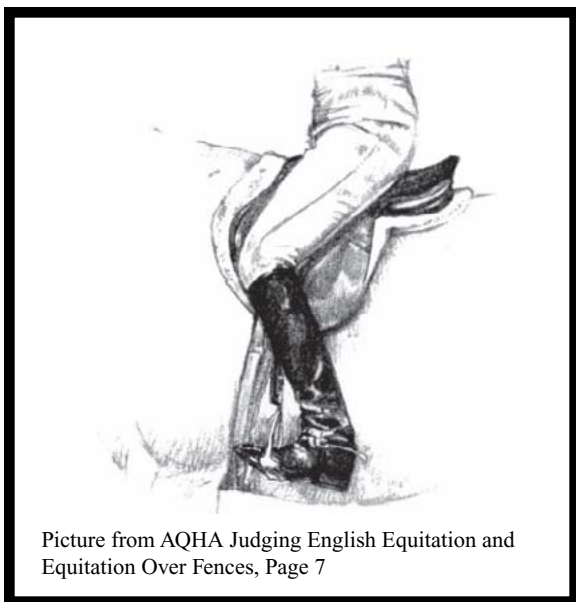
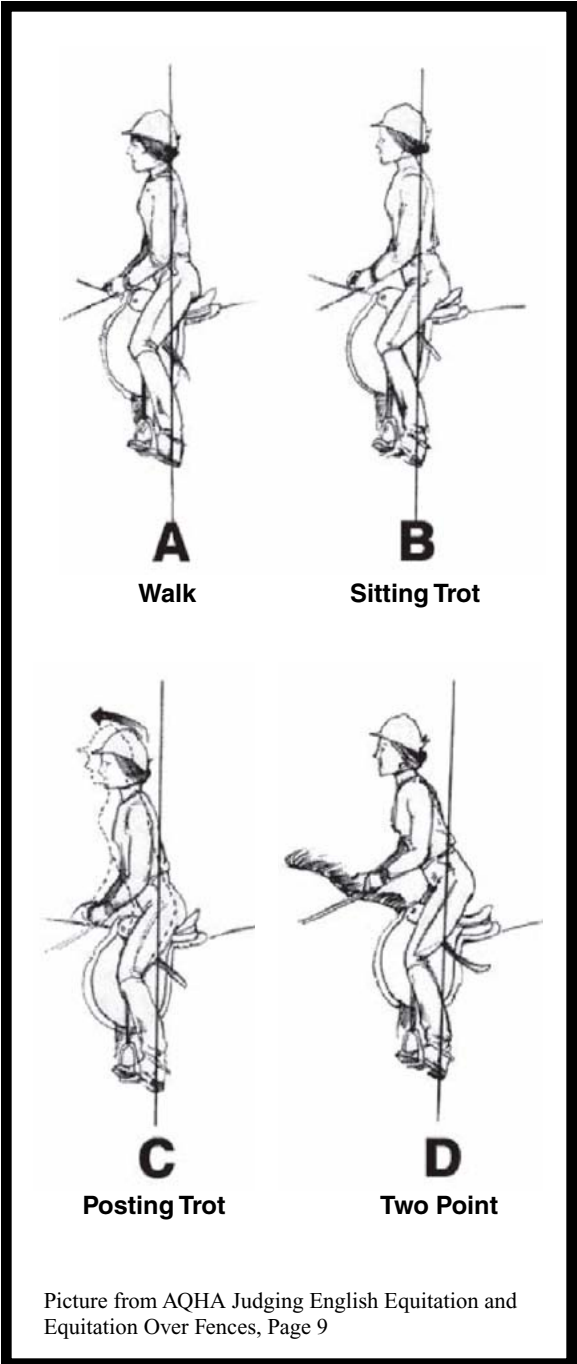

Figure 15. Correct Body Position at Different Gaits



Picture from AQHA Judging English Equitation and Equitation Over Fences, Page 9

Optional List of Tests for Hunt Seat Equitation

1. Back
2. Hand gallop
3. Halt and stand quietly
4. Figure 8 at a trot, demonstrating change of diagonals
5. Figure 8 at a canter (simple or flying lead changes)
6. Disengage feet from irons and ride without irons for a brief period of time. (No more than one minute at a trotting pace is recommended). Re-engage feet into irons.
7. Execute *serpentine* at a trot and/or canter
8. *Canter on the counter-lead*
9. Turn on the *forehand* and/or a turn on the haunches
10. Half turn and reverse. Turn off the rail, then back to the rail, resulting in a reverse of direction.
11. Change leads down the center of the ring (simple or flying lead changes)
12. Addressing the reins
13. Ride in *two-point position*

Note: These are just a few options from which the judge may choose.

Severe Faults

Should not place above any rider who does not incur a fault — may receive a white ribbon

1. Touching the horse
2. Grabbing the saddle
3. Incorrect lead or break of gait that is not fixed

Disqualifications

Should receive the lowest ribbon placing — white ribbon

1. Failure to wear correct number
2. Willful abuse
3. Spurring or cropping in front of the shoulder
4. Severe disobedience or resistance by horse, including, but not limited to, rearing, bucking or pawing
5. Loss of control of the horse
6. Excessive schooling or training
7. Broken pattern - inclusion or exclusion of maneuvers, starting the pattern on the incorrect side of the cone
8. Illegal use of hands on rein
9. Illegal equipment

■ Equitation Over Fences

Description

Equitation Over Fences is a pattern class in which contestants are given a prescribed pattern to complete. Each pattern has a set number of fences and direction of travel. The judge is looking for the rider's ability to complete the pattern with style, precision and correct body position. Except for refusals, jumping faults of the horse are not to be considered unless they are a result of the rider's ability.

Class Routine

Courses shall consist of at least six fences (a fence may be jumped more than once if so designed) but no more than eight fences should be in the course design. Each course should consist of at least one change of direction. Distances between fences shall be set at 12 foot intervals. An in-and-out with one stride between fences would be 24 feet; a two-stride at 36 feet. An in-and-out is considered as one obstacle and never must be used as a first fence (6A and 6B on Figure 16).

After entering the arena, contestants are permitted to make one courtesy circle before starting the course. Once the course is started, the participant should proceed around the course, keeping an even pace throughout. If a refusal occurs in an in-and-out, competitors must re-jump all obstacles in the combination. Once the rider has completed the course, he/she is permitted to complete a courtesy circle. A ground line shall be used on all fences with the exception of cross-rail jumps.

The suggested heights for Equitation Over Fences are as follows:

- 11 and under: 12 to 18 inches
- 12 to 14: 18 to 24 inches
- 15 and older: 24 to 30 inches

Tack and Attire

1. Refer to English Tack and Attire for Performance on pages 9 to 16.
2. **Optional:** breastplates, martingales, protective boots, neck straps for junior age group only

Scoring

A. Scale

1. Based on a score of 0-100, with the approximate break-down of:
 - a. 90-100: Excellent equitation, meets all fences squarely, keeps constant body position
 - b. 80-89: Good performer, encounters a few minor problems with distance from fences, rider still maintains a quality ride
 - c. 70-79: Average equitation, problems with body position or one fault on the fence due to the rider's cues
 - d. 60-69: Poor equitation, rider lacks the correct body position, two to three fence problems, loss of trot on a trot fence
 - e. 40-59: Severe faults, breaking to a trot on course, missed leads, loss of stirrups, drops reins
 - f. 10-39: Rider avoids elimination, but incurs one or two refusals or knockdowns, jumps fences in a dangerous manner

Figure 16. Example Course Design

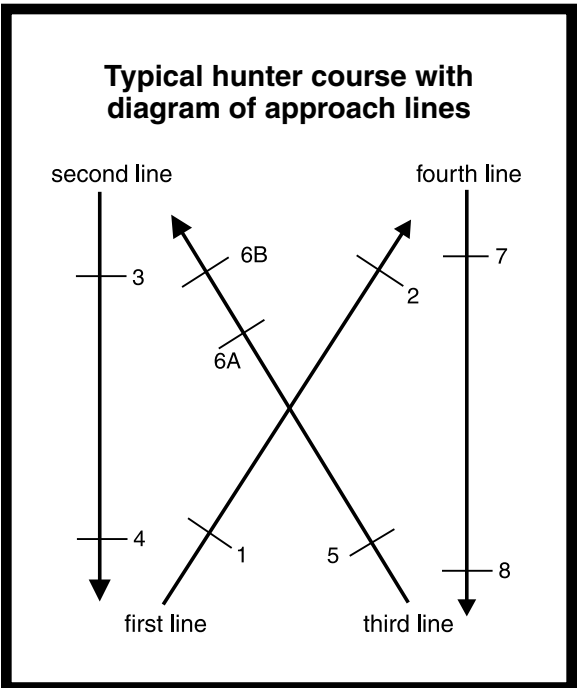

2. Credit

- a. Eyes up
- b. Correct body position
- c. Jumping fences squarely
- d. Good plan of attack for the course
- e. Release over the fences
- f. Working the course in a steady fashion
- g. Correct leads
- h. Lengthening and shortening strides to accommodate the fence lengths

3. Faults of rider

- a. Loses upper body position over or between fences
- b. Getting ahead or behind the jump
- c. Incorrect stirrup positioning
- d. Hands not moving with the motion of the horse
- e. Reins not adjusted correctly
- f. Dropping a rein
- g. Rider's legs swinging with the horse
- h. Legs out of the proper position
- i. Heels up
- j. Hands held too straight or too flat
- k. Eyes down
- l. Wrong diagonals
- m. Inconsistent pace throughout the course
- n. Adding or excluding strides
- o. Excessive controlling of the horse through the course
- p. Poor maneuvering through the course
- q. Trot on course where it is not called for
- r. Wrong lead or counter-cantering
- s. Refusal
- t. Knockdown
- u. Blatant disobedience
- v. Unnecessary circling

4. Elimination — Should receive the lowest possible ribbon — white ribbon

- a. Third **cumulative** refusal (this is for the entire course, not each jump - i.e. three refusals at one jump will result in elimination)
- b. Jumping an obstacle before it is reset
- c. Off course
- d. Horse and/or rider falling in competition

B. Body Position (Figure 17)

1. Head and Eyes
 - a. Head should be up
 - b. Eyes should be looking in the direction of travel

- c. Rider should not look down at fence or noticeably look down to check lead or diagonal
- 2. Upper Body
 - a. Shoulders should stay open and square
 - b. Hip angle should be closed more as the rider goes over the fence
 - c. Back should remain straight, not slouched or too stiff
- 3. Arms and Hands
 - a. Elbows should be bent between fences and while approaching the fences, but should straighten to release the horse as the jump is completed
 - b. Hands should be slightly tipped toward each other
- 4. Legs
 - a. Should have a slight bend
 - b. Leg position should stay at the girth
 - c. Leg should be solid and should not move with the horse
 - d. Heels should be down
 - e. Toes run parallel or slightly tipped out in a comfortable position

Figure 17. Example of Proper Body Position

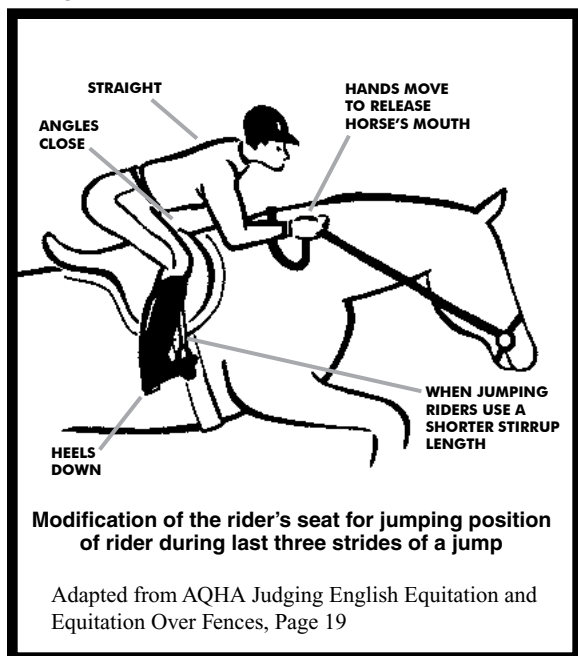

■ Hunter Hack

Description

Hunter Hack is a combination of working hunter and hunter under saddle. This class is a combination of two fences and rail work. The class is judged on rail work, obedience, style over fences, manners and a steady hunting pace.

Class Routine

Horses first will jump the two fences. These fences should be set in a line placed at any increment of 12 feet apart, but no less than 36 feet apart. A ground line is recommended for each jump. Horses should meet the fences squarely and at the center of each jump. At the discretion of the judge, riders may be asked to hand gallop, pull up or back and stand quietly following the last fence. After jumping the two fences, riders then will be asked to complete group rail work. Rail work will include walk, trot and canter, in which the judge is looking for a horse that travels and works like a hunter under saddle horse, demonstrating a free-moving, ground-covering stride while keeping a relaxed top line and traveling with light contact.

The suggested heights for Hunter Hack are as follows:

11 and under: 12 to 18 inches

12 to 14: 18 to 24 inches

15 and older: 24 to 30 inches

Tack and Attire

1. Refer to English Tack and Attire for Performance on pages 9 to 16.
2. **Optional:** breastplates
3. **Prohibited:** protective boots, martingales

Scoring

A. Scored on a scale of 0-100

1. 90-100: an excellent performer and good mover that jumps the entire course with cadence, balance and style.
2. 80-89: a good performer that jumps all fences reasonably well; an excellent performer that commits one or two minor faults.

3. 70-79: the average, fair mover that makes no serious faults, but lacks the style, cadence and good balance of the scoper horses; the good performer that makes a few minor faults.
4. 60-69: poor movers that make minor mistakes; fair or average movers that have one or two poor fences but no major faults or disobediences.
5. 50-59: a horse that commits one major fault, such as a hind knockdown, refusal, trot, cross-canter or drops a leg.
6. 30-49: a horse that commits two or more major faults, including front knockdowns and refusals, or jumps in a manner that otherwise endangers the horse and/or rider.
7. 10-29: a horse that avoids elimination but jumps in such an unsafe and dangerous manner as to preclude a higher score.

B. Jumping - 70 percent of total

1. Faults

- a. Knockdowns – major
- b. Runouts – major
- c. Disobediences – major
- d. Refusals – major
- e. Wrong lead or diagonal
- f. Unnecessary circling
- g. Excessive speed or slowness
- h. Breaking gait
- i. Stumbling
- j. Ticking or rubbing
- k. Nosing out or overflexion
- l. Failure to maintain light contact
- m. Head carriage too high or too low for the breed

2. Elimination — Should receive the lowest possible ribbon — white ribbon

- a. Three cumulative disobediences, including refusal, stop, runout or extra circling
- b. Jumping an obstacle before it is reset
- c. Bolting from the arena
- d. Off course
- e. Deliberately *addressing an obstacle*

C. Flat Work - 30 percent of total

1. Judged like a Hunter Under Saddle class

2. Credits

- a. Ground-covering and free-moving strides
- b. Impulsion
- c. Cadence
- d. Relaxed top line
- e. Prompt transitions
- f. Style and manners

3. Faults

- a. Loss of cadence
- b. Wrong leads
- c. Break of gait
- d. Excessive opening of mouth
- e. Inconsistency in speed
- f. Quick, choppy strides
- g. Failure to maintain light contact with the bit
- h. Head carried too high or too low for the breed
- i. Overflexing or nosing out

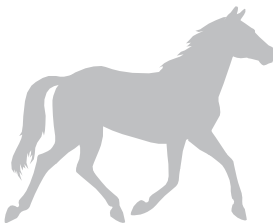

■ Hunter Under Saddle

Description

Hunter under saddle is designed to demonstrate a horse's brokeness, consistency and quality of movement. A good hunter under saddle horse should be alert, obedient and responsive to the rider. Hunter under saddle horses should possess a forward-moving, flat-footed, four-beat walk. They should show a long, low, ground-covering, cadenced two-beat trot. The canter should be a consistent, smooth, free-moving and rhythmical three-beat gait. The hand gallop is an optional gait that shows a definite lengthening of the stride with a noticeable difference in speed. When performing this gait, the horse always should be under control and easily stopped or transitioned as instructed by the judge. Horses should carry their head in a relaxed and natural position and should not be overflexed at the poll. Light contact with the horse's mouth should be maintained at all times. Horses should appear the same when traveling both directions of the arena. Horses should be judged according to their breed rules and standards.

Class Routine

Horses are to enter the arena single file either at a walk or trot as directed by the judge. Horses shall demonstrate a walk, trot and canter in both directions of the arena. Horses always should be reversed away from the rail and never should be asked to reverse at a canter. When working on the rail, slower-moving horses should remain closest to the rail and any passing should be done on the inside (toward the middle of the arena) of the slower-moving horse. Adequate space should be created between the passing horses before returning to the rail. A rider never should pass between another horse and the rail. At the judge's discretion, horses may be backed individually in the center of the arena or as a group on the rail. The judge may ask for additional work from any or all contestants, including but not limited to: extended trot or hand gallop, reverse at walk or trot, stop from any gait and transition between gaits. An extended gait should be a lengthening of the stride and more reach from the shoulder with very little change in the speed of the animal. Excessive speed will be penalized. Riders will not be asked to dismount unless the judge requests an equipment check.

Tack and Attire

1. Refer to the sections on English Tack and Attire for Performance on Pages 9 to 16.
2. Horse and saddle should be suited to the rider's ability and size.
3. Prohibited: mechanical hackamores, draw reins, tie-downs, martingales, protective boots or leg wraps, crops, bats, whips, roping reins.

Scoring

Each gait in this class should be ranked on a scale of good, average or below average. A horse receiving mostly above-average marks should receive a blue ribbon. Horses scoring average in most fields should receive a red ribbon and horses scoring below average for the majority of the class should receive a white ribbon. A description of gaits and appropriate score follows.

Hunter Under Saddle

Gait	Good	Average	Below Average
Walk	Ground-covering, flat-footed, four-beat gait, straight and true	Slow, nonrhythmical gait	Stopping and starting, nervous jogging
Trot	Smooth, two-beat diagonal gait, consistent speed, steady, cadenced, drive from the hind end, big, bold mover	Faster moving, more unsteady with head carriage, inconsistent contact with mouth, lacks drive from the hind end	Not keeping a two-beat jog, changing speed, lacks frame, breaks gait
Canter	Cadenced three-beat gait, consistent, framed, extension from shoulder, travels low to the ground	Cadenced, consistent, requires more guidance from the rider, lacks quality of movement	Unbalanced head carriage, lacking three-beat canter, excessive speed, requires continuous guidance, breaks gait

Hunter Under Saddle (continued)

Gait	Good	Average	Below Average
Extended Trot	Good lengthening of stride, stays steady with head, consistent speed	Changes speed, does not show extension from the shoulder, requires more guidance, inconsistent	Inconsistent speed, breaks gait, pushy
Hand Gallop	Forward-moving and expressive gait, horse is easily pulled up to a slower gait	Lacks some control, horse is heavy in the bridle	Lacks speed control, not easily guided, hard to pull up to a slower gait
Back	Responsive, backs straight and willingly	Slight hesitation, backing crooked	Throws head, pulls on bit, not backing
Attitude	Ears forward, tail quiet, travels with light contact, attentive to rider's cues, looks straight through the bridle when traveling, remains quiet at the bit, maintains constant speed and cadence, demonstrates smooth transitions with little handling	Horse not attentive, requires slight handling from the rider, may exhibit a combination of good and below-average qualities	Pinned ears, wringing of tail, constant chomping of the bit, horse requires constant handling by the rider, gets pushy during transitions

Severe Faults

Should not place above any rider who does not incur a fault — may receive a white ribbon

1. Incorrect lead or break of gait that is not corrected
2. Touching the horse
3. Grabbing the saddle horn or any other part of the saddle
4. Exhibiting a four-beat gait at the lope or jog
5. Excessive speed
6. Horse requires excessive handling by the rider to maintain control

Disqualifications

Should receive the lowest ribbon placing — white ribbon

1. Failure to wear correct number
2. Willful abuse
3. Spurring or cropping in front of the shoulder
4. Severe disobedience or resistance by horse, including but not limited to rearing, bucking or pawing
5. Loss of control of the horse
6. Excessive schooling or training
7. Illegal equipment
8. Illegal use of hands on rein

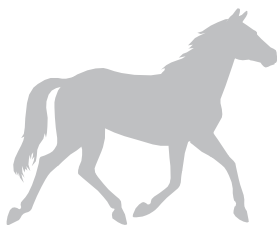

Timed Riding Classes

■ Pole Bending

Description

Pole Bending is a timed event. The Pole Bending pattern is to be run around six poles. A horse may start either to the right or left of the first pole and then run the remainder of the pattern accordingly (Figure 18).

Class Routine

Contestants are to enter the arena at a walk, and the arena gate must be closed immediately after the rider enters the arena and kept closed until pattern is completed and the horse is under control. A clearly visible start/finish line shall be provided, and the horse's nose will be timed as it crosses the start/finish line. An electric eye and backup stopwatch are recommended for timing. If an electric eye is not available, two stopwatches should be used.

Preferably, a minimum of 75 feet should be allowed for stopping from the start/finish line back to the arena fence. The distance from the start/finish line to the first pole shall be 21 feet and spacing between poles shall be 21 feet. End pole must be 20 feet, minimum, from fence.

Poles shall be set on top of the ground, be 6 feet in height and must be arranged in a straight line. Ground should be raked or renovated as warranted to maintain similar conditions for all contestants.

In the event of a tie (for the winner), the riders will re-ride to break the tie.

Tack and Attire

1. Refer to Western and English Tack and Attire for Performance on pages 9 to 16.
2. **Optional:** hackamore, gag bits, bats, crops, over and unders, tie-downs, martingales, closed reins, protective boots
3. Judges may prohibit the use of bits or equipment they consider severe.

Scoring

A. Time

1. Ribbon placings (blue, red, white) are divided based on time.
2. All ribbon divisions are at the discretion of the judge. General guidelines follow:
 - a. Blue ribbons should be awarded to the fastest times, assuming a good-quality run has been made.
 - b. Red ribbons should be awarded to times within 2.5 seconds (time may be shortened for senior riders) of the slowest blue ribbon time not to exceed 30 seconds.
 - c. White ribbons are awarded to times of 30 seconds or longer.
 - d. Blue ribbons do not have to be awarded if times do not constitute a good-quality run.
3. The judge has the final decision on all ribbon placings.

B. Penalties

1. **Five Seconds**
 - a. Knocking over a pole, per pole
 - b. Horse is led into the arena past the plane of the in-gate
2. **No time** - should receive the lowest ribbon possible - white ribbon
 - a. Pattern is started before gate is closed
 - b. Horse recrosses start/finish line at any time before pattern is completed
 - c. Extra loops in pattern
 - d. Use of bat, spurs, whip or *quirt* ahead of the cinch
 - e. Not following the Pole Bending pattern
 - f. A broken pattern shall be defined as breaking forward motion to retrace one's tracks to finish the pattern and/or passing the plane of the pole on the off side. Example: Should a contestant run by a pole and have to back up or turn around and retrace his/her tracks, this would be considered a broken pattern. Also, if a pole is knocked down and the contestant does not follow the weave pattern around the original base position of the fallen pole, it is considered a broken pattern.

■ Barrel Racing

Description

Barrel Racing is a timed event. The cloverleaf pattern is the only approved pattern for Barrel Racing (Figure 19). A horse may start either to the right or left barrel and then run the remainder of the pattern accordingly.

Class Routine

Contestants are to enter the arena at a walk, and the arena gate must be closed immediately after the rider enters the arena and kept closed until pattern is completed and the horse is under control. A clearly visible start/finish line shall be provided, and the horse's nose will be timed as it crosses the start/finish line. An electric eye and backup stopwatch are recommended for timing. If an electric eye is not available, two stopwatches should be used.

The arena conditions will determine the distance the barrels can be apart, provided they are at least 20 feet from the fence. Barrels 1 and 2 shall be 20 yards (60 feet), maximum, from the start/finish line. The maximum distance between barrels 1 and 2 shall be 30 yards (90 feet). The maximum distance between barrels 1 and 2 and barrel 3 shall be 35 yards (105 feet). Preferably, a minimum of 75 feet should be allowed for stopping from the start/finish line back to the arena fence.

In the event of a tie (for the winner), the riders will re-ride to break the tie.

Tack and Attire

1. Refer to Western and Tack and Attire for Performance on pages 9 to 16.
2. **Optional:** hackamore, gag bits, bats, crops, over and unders, tie-downs, martingales, closed reins, protective boots
3. Judges may prohibit the use of bits or equipment they consider severe.

Scoring

A. Time

1. Ribbon placings (blue, red, white) are divided based on time.
2. All ribbon divisions are at the discretion of the judge. General guidelines follow:
 - a. Blue ribbons should be awarded to the fastest times, assuming a good-quality run has been made.
 - b. Red ribbons should be awarded to times within 2 seconds (time may be shortened for senior riders) of the slowest blue ribbon time.
 - c. White ribbons are awarded to times slower than the red ribbon category.
 - d. Blue ribbons do not have to be awarded if times do not constitute a good-quality run.
3. The judge has the final decision on all ribbon placings.

B. Penalties

1. Five Second

- a. Knocking over a barrel, per barrel
- b. Horse is led into the arena past the plane of the in-gate

2. **No Time - should receive the lowest ribbon placing - white ribbon**

- a. Pattern is started before gate is closed
- b. Horse recrosses start/finish line at any time before pattern is completed
- c. Extra loops in the pattern
- d. Use of bat, spurs, whip or quirt ahead of the cinch
- e. Not following the cloverleaf pattern
- f. A broken pattern shall be defined as breaking their forward motion to retrace their tracks to finish the pattern and/or passing the plane of the barrel on the off side. Example: Should a contestant run by a barrel and have to back up or turn around and retrace his/her tracks, this would be considered a broken pattern.

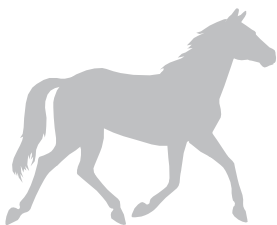
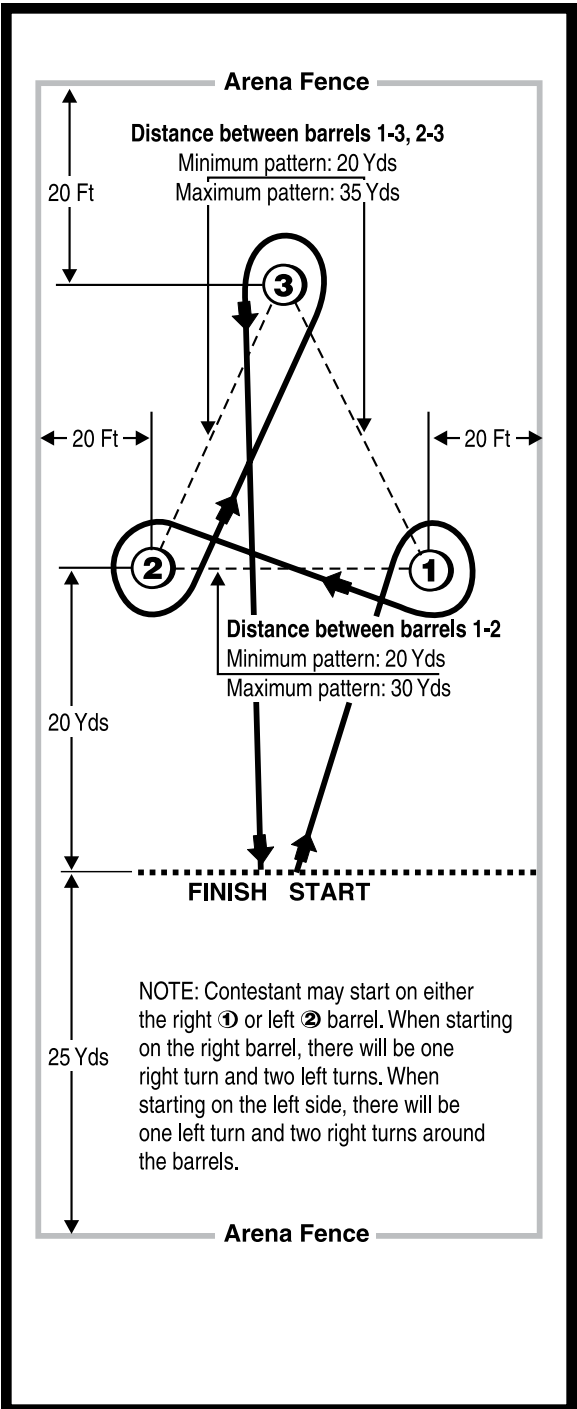

Figure 19. Barrel Racing Pattern



■ Goat Tying

Description

Goat tying is a timed event (30-second time limit). Time will be taken between two flags. A clearly visible start line shall be provided and the horse's nose will be timed as the start when it crosses the start line. Time stops when the contestant signals the completion of the tie.

Class Routine

Contestants are to enter the arena at a walk and the arena gate must be closed immediately after the rider enters the arena and be kept closed until the run is finished and the horse is caught and under control.

The contestant must be mounted on a horse when entering the arena and must ride from the starting line to the goat, dismount from his or her horse, throw the goat by hand and cross, wrap and tie by hand at least three feet together with a leather string, pigging string or rope. Boys may use calf-tying pigging string (in which the front foot is strung, then feet are wrapped and tied). No wire is to be used in the goat string. If the goat is down when the contestant reaches it, the goat must be elevated high enough that it has the opportunity to regain its feet.

Legs must remain crossed and secure for six seconds after completion of the tie. The contestant must move away from goat a minimum of 3 feet before the six-second time limit on the tie will start. During the six-second time period, the contestant will make no gestures, motions or noises to distract the goat. This will be considered trying to take unfair advantage and will result in a disqualification. To qualify as a legal tie, the contestant must make at least one complete wrap around at least three legs and a half hitch, hooey or knot. The contestant must tie the goat by hand with no pre-made wraps, coils, knots, hooeys or half hitches.

The arena gate that is entered should be at least 15 yards from the starting line. No set distance from the starting line to the stake is required, but 100 feet is desirable. Arena conditions should govern distance. The goat is to be tied to a stake with a rope that is 10 feet in length from snap to snap. The stake is to be pounded completely into the ground with no part of it visible. The stake is to be placed in the ground for the entire event. The stake shall be a minimum of 50 feet from the back fence.

In the event of a tie (for the winner), the riders will re-ride to break the tie.

Goats

Goats must be uniform in size and weight (40 to 50 pounds). The goat must be held by the collar at the end of the rope in a vertical position from the starting line until time begins (when the flag drops for the start of time, the goat holder then must release the goat and move to a position that is clear of the goat and the field flagger). Collars should be the same and snug. All goats to be used will be tied a maximum of five times before another run on the goats can begin. Enough goats must be supplied so that no more than 15 contestants will be required to tie the same goat. The following scale shall be used:

# of Contestants	# of Goats
1 – 45	4
46 – 60	5
61 – 80	6
81 – 100	7

The procedure used to draw goats shall be as follows:

All available goats, based upon the required number in the herd, will be used. The draw must take place in a public place and be posted prior to the event starting.

Example:

Contestants Entered: 22
Goats in the Herd: 4
Goat Tag Numbers: 1, 2, 3, 4
Random Draw Was: 3, 1, 2, 4, 2

Contestant Order:

Contestants #	Goat #
1	3
2	3
3	3
4	3
5	3
6	1
7	1
8	1
9	1
10	1
11	2
12	2
13	2
14	2
15	2

Contestants #	Goat #
16	4
17	4
18	4
19	4
20	4
21	2
22	2

Once draw has been posted, all “nonties” (un-notified turn-outs, goat did not stay tied for required six seconds, etc.) shall be counted as a run on a goat. For example:

Contestant #	Goat #	Time
1	3	10.57
2	3	11.23
3	3	11.62
4	3	Did not show up
5	3	15.89
6	1	22.62
7	1	14.22
8	1	No time (did not stay tied for six seconds)
9	1	9.87
10	1	16.14
11	2	21.51
Etc.	Etc.	Etc.

Tack and Attire

1. Refer to Western and Tack and Attire for Performance on Pages 9 to 16.
2. **Optional:** hackamore, gag bits, bats, crops, over and unders, tie-downs, martingales, closed reins, protective boots.
3. Judges may prohibit the use of bits or equipment they consider severe.

Scoring

A. Time

1. Ribbon placings (blue, red, white) are divided based on time.
2. All ribbon divisions are at the discretion of the judge. General guidelines follow:
 - a. Blue ribbons should be awarded to the fastest times, assuming a good-quality run has been made.
 - b. Red ribbons should be awarded to times within 2.5 seconds (time may be shortened for senior riders) of the slowest blue ribbon time.
 - c. White ribbons are awarded to times slower than the red ribbon category.
 - d. Blue ribbons do not have to be awarded if times do not constitute a good-quality run.
3. The judge has the final decision on all ribbon placings.

B. Penalties

1. Five Second

- a. Horse is led into arena past the plane of the in-gate

2. Ten Second

- a. Horse crosses over the rope or goat, or if the contestant's horse comes in contact with the goat or rope prior to the contestant signaling for time

3. No Time

- a. Run is started before gate is closed
- b. Use of bat, spurs, whip, quirt, over and under, etc., ahead of the cinch
- c. Tie does not stay secure for six seconds
- d. If the goat should break away because of the fault of the horse

- e. Runs longer than 30 seconds

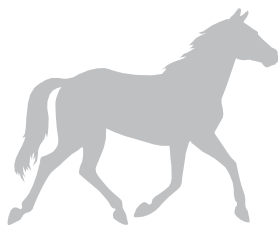

■ Keyhole

Description

Keyhole is a timed event. The Keyhole pattern is to be run in between four poles. Contestants run between the poles, turn around (may turn around either direction) and run back through the same four poles (Figure 20).

Class Routine

Contestants are to enter the arena at a walk. The arena gate must be closed immediately after the rider enters the arena and kept closed until the pattern is completed and the horse is under control.

A clearly visible start/finish line shall be provided, and the horse's nose will be timed as it crosses the start/finish line. An electric eye and backup stopwatch is recommended for timing. If an electric eye is not available, two stopwatches should be used.

The arena conditions will determine the distance from the start/finish line to the neck of the keyhole. The keyhole pattern should be 75 feet from the start/finish line to the first two poles of the keyhole neck.

The length of the keyhole neck shall be 10 feet between poles for all age divisions. The width of the keyhole neck will be 6 feet for the junior division, 5 feet for the intermediate division and 4 feet for the senior division. (If show management prefers to only use one width for all divisions, the 5 feet width should be used).

A minimum of 30 feet will be provided from the back two poles of the keyhole neck to the back fence to allow adequate distance for the horse to turn around. Preferably, a minimum of 75 feet should be allowed for stopping from the start/finish line back to the arena fence.

Poles shall be set on top of the ground 6 feet in height and must be arranged in a straight line. The ground should be raked or renovated as warranted to maintain similar conditions for all contestants.

In the event of a tie (for the winner), the riders will re-ride to break the tie.

Tack and Attire

1. Refer to Western and Tack and Attire for Performance on Pages 9 to 16.
2. **Optional:** hackamore, gag bits, bats, crops, over and unders, tie-downs, martingales, closed reins, protective boots
3. Judges may prohibit the use of bits or equipment they consider severe.

Scoring

A. Time

1. Ribbon placings (blue, red, white) are divided based on time.
2. All ribbon divisions are at the discretion of the judge.

General guidelines:

- a. Blue ribbons should be awarded to the fastest times, assuming a good-quality run has been made.
 - b. Red ribbons should be awarded to times within two seconds (time may be shortened for senior riders) of the slowest blue ribbon time not to exceed 30 seconds.
 - c. White ribbons are awarded to times of 30 seconds or longer.
 - d. Blue ribbons do not have to be awarded if times do not constitute a good-quality run.
3. The judge has the final decision on all ribbon placings.

B. Penalties

1. **Five Seconds**
 - a. Knocking over a pole, per pole
 - b. Horse is led into the arena past the plane of the in-gate
2. **No time** – should receive the lowest ribbon possible – white ribbon
 - a. Pattern is started before gate is closed
 - b. Horse recrosses start/finish line at any time before pattern is completed
 - c. Extra loops in pattern
 - d. Use of bat, spurs, whip or *quirt* ahead of the cinch
 - e. Not following the Keyhole pattern
 - f. A broken pattern shall be defined as breaking forward motion to retrace one's tracks to finish the pattern and/or passing the plane of the pole on the off side.

Example: Should a contestant not enter into the neck of the keyhole and have to back up or turn around and retrace his/her tracks, this would be considered a broken pattern. Also, if a contestant does not go through the neck completely (horse weaves out of pattern between poles) either on the way into the keyhole or on the way out of the keyhole, this would be considered a broken pattern.

Figure 20. Keyhole Pattern

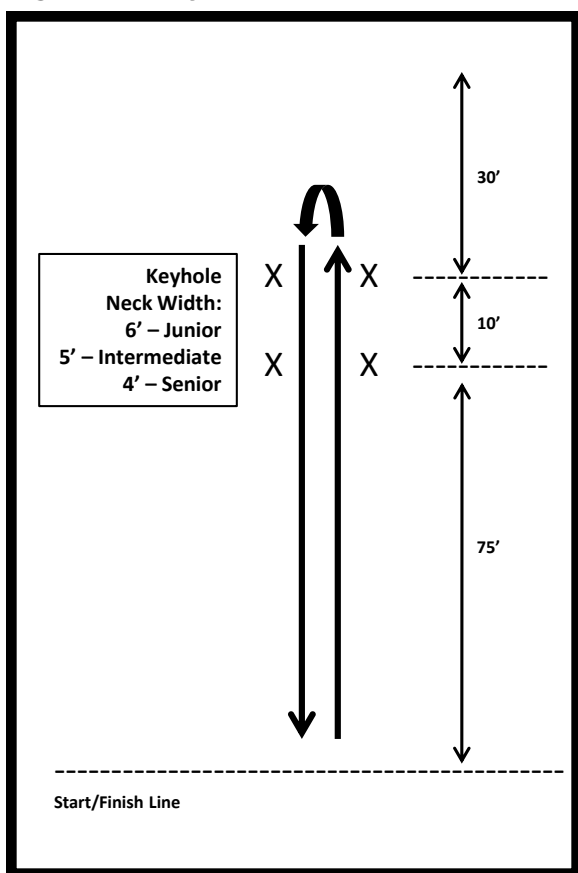

Horse Show Operation and Judging Guide

This rulebook sets the standards for 4-H leaders, participants, show management and Extension educators to help establish uniformity in judging procedures at 4-H horse events.

Objectives

The purpose of the horse project is to help North Dakota youth:

1. In character development
2. Develop leadership, work ethic, sportsmanship and other desirable character traits
3. Prepare for citizenship responsibilities by working together in groups and supporting community horse projects and activities
4. Acquire skills and basic knowledge in horsemanship
5. Develop a sense of ethics in animal husbandry
6. Experience pride in owning, managing and caring for horses

Use of 4-H Name and Emblem at Horse Shows

1. When the letters “4-H” or the emblem of the four-leaf clover is used in connection with any horse show, the management must have in writing the approval of the NDSU Extension Service county office or Center for 4-H Youth Development.
2. Individuals or organizations sponsoring horse shows for their individual gain need to use “Junior Horse Show,” not “4-H Horse Show.”
3. The official 4-H emblem consists of a green, four-leaf clover with a stem and the letter “H” in white or gold on each leaflet. When used, the 4-H club name and emblem must be given a position of prominence. Superimposing any letter, design or object on the 4-H emblem or altering its shape is not permissible. The emblem must include the 18 U.S.C. 707 identification.

General Horse Show Management Considerations

1. Make a general announcement giving the date, time and location of the show and the name of the judge in advance of the show. The general announcement needs to tell when, where and how participants are to make entries.
2. Post diagrams of all courses and patterns one hour prior to the class.
3. Refer questions regarding conduct of the show immediately to the superintendent of the show. The show superintendent needs to confer with other show officials and judges, if necessary, and give an on-the-spot decision that will be accepted as final.
4. Decisions of the judge are final. The management will ask the judges to make a reasonable effort to give reasons for final placings.
5. Where the number of entries is large, management reserves the right to have preliminary selections made in any class and to further divide the class.
6. Call each class at least three times, including a "last call."
7. Sportsmanship is important at all times. Unnecessary roughness or discourteous behavior will dismiss the rider from further competition for the entire show.
8. Management should provide the following:
 - a. Show ring of adequate size, recommended minimum 100 feet by 200 feet
 - b. Equipment for officials
 - c. Space for parking and spectator seating
 - d. Exercise area for exhibitors
 - e. Restrooms, food, drinking water and other considerations for the comfort of exhibitors and spectators

Judging 4-H Horse Shows

4-H horse show exhibitors look to the judge for expertise in showmanship and horse judging. They expect the judge to be familiar with the requirements for the various breeds and are grateful for encouragement and constructive criticism.

Regardless of the breed being judged, the emphasis in 4-H shows is on the exhibitors. Evaluate participants on their ability to present themselves and their horse, pony or mule to the best advantage. The exhibitor's knowledge of how to groom, trim and show a horse according to the accepted breed standards is important. Conformation of the horse is not a factor. Classes shown under saddle are judged on manners and performance that reflect on the member's training, riding and showing ability. Suitability of tack and how it fits, or whether the horse, tack and clothing are clean, are considered.

Qualified 4-H Judges

Show management is strongly encouraged to hire a judge from the North Dakota certified 4-H horse show judges list. These judges are required to attend a recertification course and take a test on the current rules in 4-H with the goal of keeping judging standards uniform and fair throughout the state. Lists of judges are available at NDSU Extension Service county offices.

Danish System

North Dakota 4-H competitions are to use the Danish system of judging. In the Danish system, competitors are ranked by measuring quality against a predetermined standard and the fulfillment of exhibit requirements. The Danish system requires that each competitor be compared with a predetermined standard of excellence and awarded a blue, red or white ribbon based on those standards. In the Danish system, exhibitors within a class never are compared with one another as they are when judged under the standard ranking system.

Modified Danish System

Some shows select first and second place (champion or reserve champion) or perhaps as many as six places using the standard ranking system after exhibitors are placed into a ribbon category using the Danish system.

Suggested general guidelines for placing under the Danish system

Blue ribbon — Outstanding or excellent performance. The exhibitor has met and/or exceeded basic requirements of the class. One or two minor faults, if immediately corrected, do not eliminate an exhibitor from the blue ribbon category.

Red ribbon — Good performer. An exhibitor completed the required work but with an accumulation of faults: missed leads, broken gaits, excessive speed, lack of coordination, poor equitation, poor grooming or dirty or poor-fitting tack.

White ribbon — Below-average performer who needs improvement and did not meet the requirements of the class. An exhibitor completed the class but with some major faults or broken patterns: inability to execute and maintain a required gait or performing in wrong lead without attempting to make a correction.

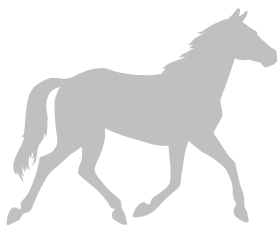

Glossary

Addressing an obstacle is a term used to describe allowing the horse to inspect a jump or an obstacle on a jumping course and is typically not allowed.

Bight of rein is the part of rein passing between a thumb and fingers and out the top of the hand; the excess rein.

Bosal is a noseband made of braided rawhide utilized by western riders. The bosal should rest quietly on the nose of the horse until the reins are moved. A bosal is ridden with two hands on the reins.

Breeches are fitted riding pants that are worn on the inside of the boot; the knee area is generally made of suede; common colors are canary, tan, rust and grey.

Cavesson is a nose band on a bridle used to keep the horse's mouth shut for better control.

Counter-canter is a horse leading with outside leg when cantering in a circle (wrong lead).

Cross-canter is a horse cantering on one lead with the front legs and the opposite lead with the hind legs.

Curb (also called a shank bit) is a bit with a solid or broken mouthpiece that has shanks for attachment of the reins. Curb bits are to be ridden with one hand on the reins. Any bit that works by leverage is considered a curb bit.

Diagonal is an imaginary line running from the near hind to the off forefoot of a horse. To ride on the correct diagonal, the rider rises out of the saddle when the outside front leg is farthest forward. Change of direction calls for a change of diagonal. The rider sits in the saddle for one beat or step and rises on the opposite diagonal. This is done without disturbing the rhythm of the trot. Correct diagonals are necessary for a truly straight and balanced horse, whether riding in a circle or in a straight line.

Equitation is the art of riding horseback; horsemanship.

Forehand is the fore part of the horse - the forelegs, head and shoulders.

Full bridle has two bits, a snaffle and a curb. The snaffle sits higher in the horse's mouth than the curb. This type of bridle allows the rider to have the benefits of both the snaffle and the flexion of the curb. Four reins are attached to this bridle. The wider reins go to the snaffle. From left to right, the reins are held left snaffle-curb-curb-snaffle.

Girth is the measure of the circumference of a horse's body back of the withers. It is also a leather, canvas or corded piece around the body of the horse to hold the saddle on the horse.

Hackamore is a type of bridle that does not have a bit. It works by providing pressure on the horse's face, nose, and chin. Hackamores can be made of leather, cable, rope, plastic or rawhide and may have metal parts. Mechanical hackamores have long shanks that attach to the noseband and have leverage action; they are illegal in many show classes.

Hunt seat is a jumping saddle with a deep seat, which may have knee rolls. The stirrups are shorter than in other seats.

Junior horse is a horse that is five years old or younger.

Kimberwick is a bit used for English riding with D-ring cheek pieces that are offset from the mouthpiece. This attachment allows the bit to act with a small amount of leverage action giving it a mild curb bit effect.

Pelham is a bit that incorporates the action of both a curb and a snaffle by use of two sets of reins. The mouthpiece is solid with or without a port. The shank has an extra ring to which a "snaffle rein" is attached. Unlike the full bridle, both actions come from the same bit.

Port is the part of a solid mouthpiece bit that bends upward to the roof of the horse's mouth.

Posting is the rising and descending of the rider with the rhythm of the trot.

Quarters system is a system utilized in showmanship whereby the horse is divided into four quarters. The handler should always be one quadrant away from the judge, and thus is on the opposite side of the horse from the judge when the judge is toward the front of the horse, and on the same side when the judge is toward the rear of the horse. The handler should always have a clear view of the judge.

Quirt is a riding whip with a short handle and a lash of braided rawhide.

Romal is an extension of braided material attached to closed reins.

Senior horse is a horse that is six years or older.

Serpentine is a series of equal curves from one side of the centerline to the other, changing the direction of the turn each time the horse passes over the centerline. It requires a change of diagonals at a trot and a change of lead at the canter.

Sliding plates are smooth, flat shoes placed on the hind feet of a horse that enable the hindlegs to slide along the ground as a horse comes to a stop.

Snaffle is a bit with a broken mouthpiece and no shanks. Reins attach directly to D-ring, O-ring, or eggbutt check pieces. Snaffle bits act through direct pressure on the horse's mouth. Snaffle bits are designed to be ridden with two hands on the reins.

Two-point position is also known as jumping position. In two-point position there are two points of the rider's body in contact with the saddle (the rider's legs) as opposed to three points (seat and two legs). In proper two-point position the rider should have their seat out of the saddle, their body inclined forward from the hips with their hands moved up on the crest of the neck, elbows bent, with their lower leg's underneath their body and their heels down.

County commissions, North Dakota State University and U.S. Department of Agriculture cooperating. North Dakota State University does not discriminate on the basis of age, color, disability, gender expression/identity, genetic information, marital status, national origin, public assistance status, race, religion, sex, sexual orientation, or status as a U.S. veteran. Direct inquiries to the Vice President for Equity, Diversity and Global Outreach, 205 Old Main, (701) 231-7708. This publication will be made available in alternative formats for people with disabilities upon request, (701) 231-7881.

300-11-10, 300-1-10, 300-2-08, 500-7-06, 600-7-04, 250-6-02

